

**TECHNICAL MANUAL**

**OPERATOR'S, ORGANIZATIONAL,  
DIRECT SUPPORT, AND GENERAL SUPPORT  
MAINTENANCE MANUAL**

**FOR**

**MERCURIAL ALTITUDE TEST BAROMETER  
TYPE A-1 (6685-511-9864)**

**AND**

**METRIC MERCURIAL BAROMETER  
TYPE A-1 MODIFIED (6660-182-7792)**

**This copy is a reprint which includes current  
pages from Change 1.**

---

**HEADQUARTERS, DEPARTMENT OF THE ARMY**

**SEPTEMBER 1972**

**OPERATOR'S, ORGANIZATIONAL, DIRECT SUPPORT,  
AND GENERAL SUPPORT MAINTENANCE MANUAL  
FOR  
MERCURIAL ALTITUDE TEST BAROMETER  
TYPE A-1 (6685-511-9864) AND  
METRIC MERCURIAL BAROMETER TYPE  
A-1 (MODIFIED) (6660-182-7792)**

		Paragraph	Page
CHAPTER	1.	INTRODUCTION	
Section	I.	General ..... 1-1	1-1
	II.	Description and Data ..... 1-7	1-2
CHAPTER	2.	THEORY OF OPERATION	
Section	I.	General Operation ..... 2-1	2-1
	II.	Functional Description ..... 2-2	2-1
CHAPTER	3.	OPERATING INSTRUCTIONS	
Section	I.	Service Upon Receipt of Material ..... 3-1	3-1
	II.	Operation Under Usual Conditions ..... 3-6	3-6
CHAPTER	4.	MAINTENANCE INSTRUCTIONS	
Section	I.	Parts, Special Tools, and Equipment for Operators ..... 4-1	4-1
	II.	Preventative Maintenance Services ..... 4-3	4-1
	III.	Troubleshooting ..... 4-9	4-8
	IV.	Corrective Maintenance ..... 4-11	4-10
CHAPTER	5.	SHIPMENT, STORAGE, AND DESTRUCTION OF MATERIAL TO PREVENT ENEMY USE ..... 5-1	5-1
APPENDIX	A.	References ..... A-1	A-1
APPENDIX	B.	Maintenance Allocation Chart ..... B-1	B-1
APPENDIX	C.	Basic Issue Items List, Repair Parts List, and Items Troop Installed or Authorized List	

\_\_\_\_\_ This manual supersedes TM 9-6685-202-15, 24 September 1964.

Section	I.	Introduction .....	C-1	C-1
	II.	Basic Issue Items List .....		C-2
	III.	Repair Parts List .....		C-9
	IV.	Items Troop Installed or Authorized List (Not Applicable)		

INDEX.....	INDEX - 1
------------	-----------

**List of Illustrations**

Figure	Title	Page
1-1	Type A-1 mercurial altitude test barometer and metric mercurial barometer (modified) .....	1-3
1-2	Location and identification of components (modified and unmodified) .....	1-4
1-3	Computing - correcting mechanism - front view .....	1-6
1-4	Computing - correcting mechanism - rear view .....	1-7
3-1	Mercury locking screw adjustment .....	3-3
3-2	Gravity correction chart .....	3-5
3-3	Constant vacuum regulator - operated under vacuum .....	3-8
3-4	Sighting the mercury level .....	3-9
3-5	Vernier scale and indexes - (type A-1) .....	3-11
3-6	Scale and vernier - (type A-1 modified) .....	3-12
3-7	Cistern micrometer .....	3-13
3-8	Altimeter calibration - operating setup.....	3-15
4-1	Removal of mercury .....	4-5
4-2	Installation of mercury - (type A-1 modified) .....	4-6
4-3	Removal of subassemblies .....	4-11
4-4	Disassembly of valve subassembly .....	4-12
4-5	Disassembly of temperature and gravity scale .....	4-14
	assembly .....	4-16
4-6	Disassembly of vernier slide assembly .....	4-18
4-7	Disassembly of cistern base assembly .....	4-20
4-8	Disassembly of platform assembly .....	4-22
4-9	Disassembly of vacuum pump - 4310-203-3057 .....	4-25
4-10	Disassembly of vacuum pump - 4931-929-8403 .....	4-27
4-11	Disassembly of constant vacuum regulator .....	4-29
4-12	Installation of gland nut .....	3-4

## CHAPTER I

### INTRODUCTION

---

#### Section I. GENERAL

##### 1-1. Scope

a. This manual contains instructions for the operation and maintenance of the Mercurial Altitude Test Barometer Type A-1, 6685-511-9864 and the Metric Mercurial Barometer Type A-1 Modified, 6660-1827792. The barometers are utilized to supply the measurement accuracies required to support pertinent Army materiel and to calibrate other mercurial or aneroid barometers of the same or lesser accuracy. The manual also contains the description and theory of operation as well as information on the operation and maintenance of associated equipment.

b. Appendix A contains a list of current references, including supply catalogs, technical manuals, and other related publications applicable to the barometer.

c. Appendix B contains the maintenance allocation chart. It specifies the level of responsibilities of maintenance with regard to the service and repair to be performed on the barometers.

d. Appendix C contains the basic issue items list which lists items furnished with the barometer, and a list of repair parts that are normally required to repair and maintain the barometer.

##### 1-2. Maintenance Allocation

a. The authorized maintenance responsibilities will be limited to those functions prescribed by the maintenance allocation chart (MAC). When the nature of repairs, modifications or adjustments is beyond the scope or facilities of the using personnel, the responsible maintenance or repair unit will be informed in order that trained, qualified personnel with proper tools and equipment can perform the necessary functions.

b. Some repair parts are available to support this materiel in the Army supply system. Procurement of repair parts will be accomplished in accordance with TM 9-4931-700-34P-1, Direct Support and General Support Maintenance Repair Parts and Special Tools List for Calibration Standards Sets.

##### 1-3. Maintenance Technique

a. The IROAN (Inspection and Repair Only as Necessary) maintenance technique will be used to restore this materiel to a serviceable condition.

b. The IROAN maintenance technique is the systematic isolation and remedy of a malfunctioning or defective component through test, diagnosis, and repair. No component of the materiel is disassembled before a definite requirement for disassembly has been established.

##### 1-4. Differences Among Models

a. The type A-1 mercurial altitude test barometer is manufactured by the Bass Instrument Corporation, Washington, D. C. Barometers, serial numbers 6 to 248, were manufactured in accordance with USAF Specification Number 27022. Serial numbers 276 to 836 were manufactured in accordance with MIL-B-4308 specification. Serial number 1100 and subsequent were manufactured in accordance with MIL-B-4308B specification.

b. The manufacturer's part number is 10-00-00-F for the latest model described in this manual. However, there are older models currently in use with different measurement capabilities. The barometers with part numbers 10-00-00-A and -D are designed to be correct at 0°C (32°F) and 980.665 cm/sec<sup>2</sup>. Barometers with part number 10-00-00-F are designed to indicate correctly at 25°C (77°F) and 980.665 cm/sec<sup>2</sup>. Serial numbers 10 through 46 are designated as model A, while models B, C, and E do not conform to any particular serial numbering sequence. Serial numbers 47 through 402 are classified as model D, while serial numbers 450 through 1099 are classified as model F.

Model G is serial numbered 1100 through 1199, model H, 1300 through 1799 and model J, 2100 up.

c. Earlier models may be rebuilt with components applicable to current models. If variations among models cause procedural differences, notes in the text will provide alternate data.

d. Approximately 64 barometers have been modified, without regard to any specific serial number sequence, to provide a higher degree of accuracy for calibration purposes. The modified barometer APN 7913093, FSN 6660-182-7792, is equipped with a metric micrometer in the barometer cistern and a 0 to 820-mm true-length scale and vernier-set on the barometer mercury column tube. In addition, a vacuum gage and sensor element with the associated tubing and connectors have been added to the top cylinder mounting disk. A gage block mount is also added to the

base of the barometer tube to provide a more accurate calibration of the barometer.

### 1-5. Forms, Records, and Reports

Refer to TM 38-750 for instructions on the use and completion of all forms required for operating and maintaining the equipment.

### 1-6. Reporting of Errors

The reporting of errors, omissions, and recommendations for improving this publication by the individual user is encouraged. Reports should be submitted on DA Forms 2028 (Recommended Changes to Publications) and forwarded direct to Commanding General, US Army Missile Command, ATTN: AMSMI-MFPB, Redstone Arsenal, AL 35809.

## Section II. DESCRIPTION AND DATA

### 1-7. Description

a. *Type A-1.* The type A-1 barometer (fig. 1-1) consists of a precision bore glass tube rising out of a fixed cistern. The tube is supported by a frame set on a mounting platform. The cistern is also a precision bore glass cylinder and is mounted on the barometer base

and connected to the tube through a passage in the base. The barometer is equipped with a compensating system which compensates and applies corrections for deviations from standard temperature and gravity. The various components that comprise the barometer are located and identified in figure 1-2.

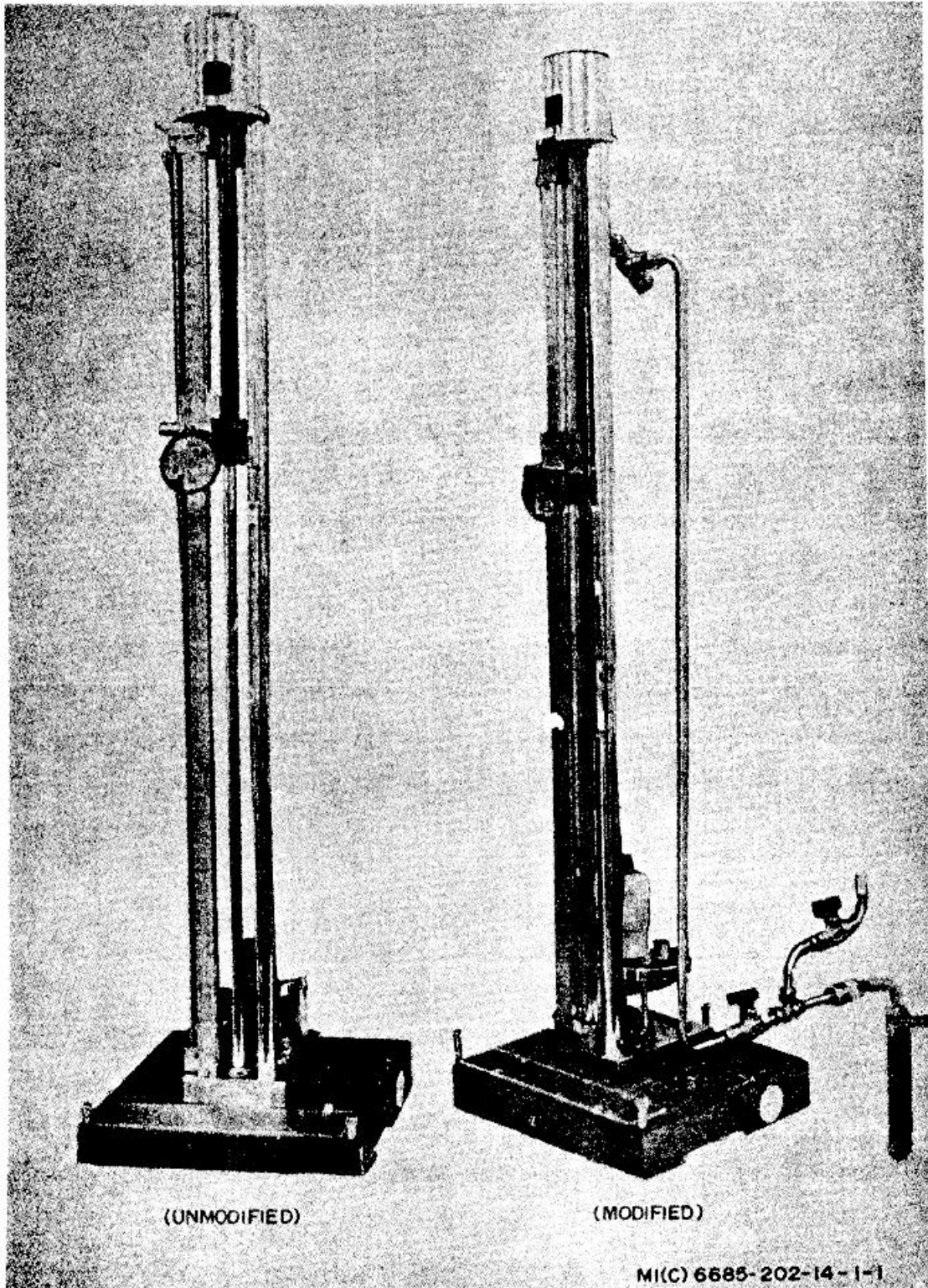

Figure 1-1. Type A-1 mercurial altitude test barometer and metric mercurial barometer (modified)

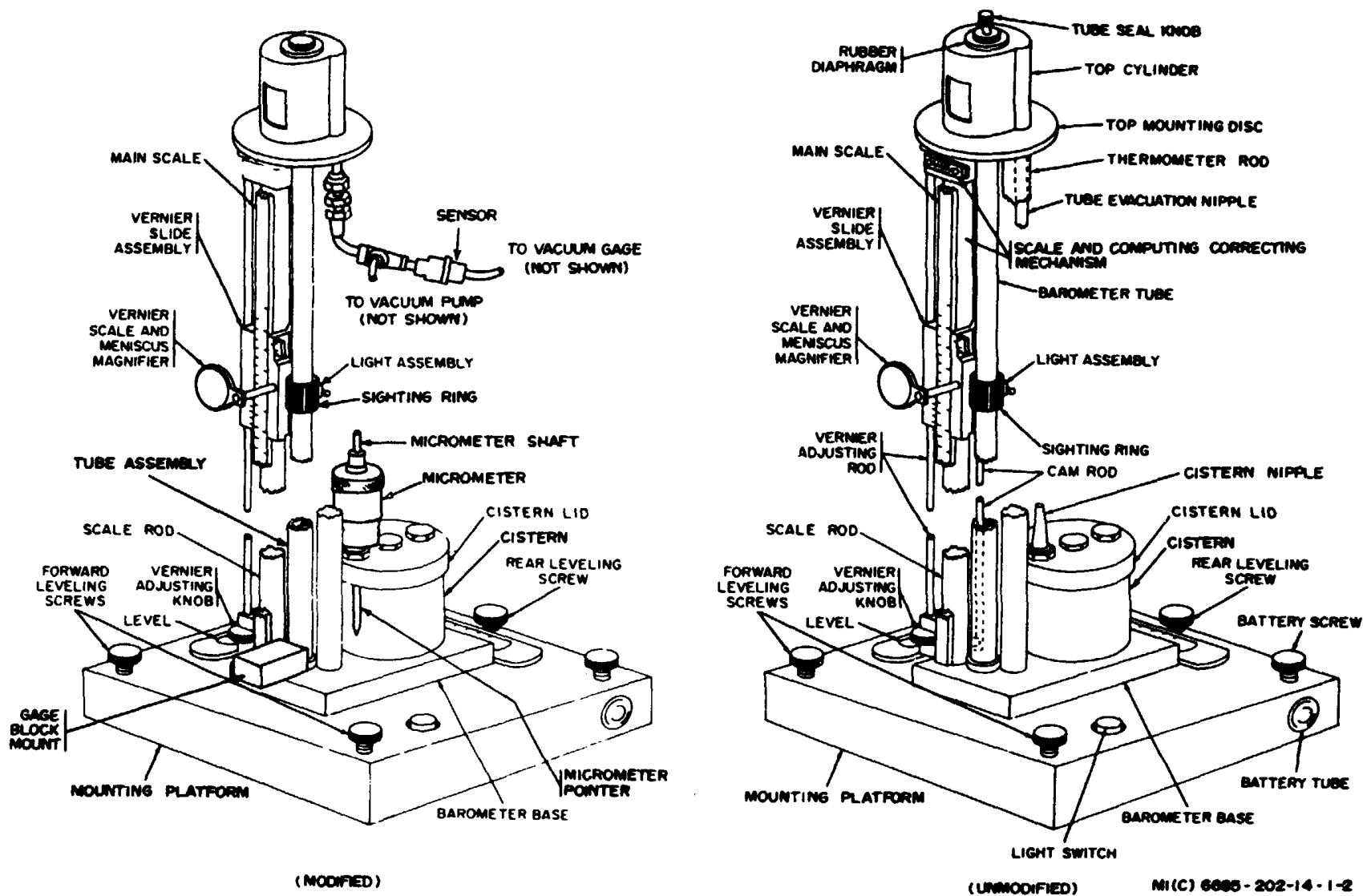

Figure 1-2. Location and identification of components (modified and unmodified)

(1) *Mounting Platform Assembly.* The mounting platform (fig. 1-2) serves as a level platform for mounting the barometer proper. Two sensitive bubble levels and three leveling screws are provided. A battery compartment, a pushbutton switch for the light, and the calibration curve for the instrument are also included.

(2) *Cistern and Base Assembly.* The mounting platform (fig. 1-2) consists of a stainless steel base on which is mounted the cistern, the barometer base, and the barometer tube. The cistern is a precision bore pyrex cylinder. The barometer base incorporates a connecting passage between the cistern and the barometer tube which can be blocked to seal all mercury in the cistern during shipment of the barometer. The cistern is pressure sealed with gaskets to the base on the lower end and to a cistern lid at the upper end. The lid incorporates a cistern nipple and gasket for connecting the barometer to a pneumatic system under test, and a plugged hole to facilitate emptying the cistern. The barometer base is fastened to the mounting platform by two hexagon socket head screws which thread into tapped holes in the platform assembly from the top of the base.

(3) *Barometer Frame Assembly.* The frame assembly is composed of two 7/8 inch diameter rods mounted vertically on the barometer base (fig. 1-2) on either side of the barometer tube. The upper end of each rod is fastened to a top mounting disc which also provides support for the upper end of the barometer tube. The left-hand rod known as the scale rod, carries the scale, vernier slide assembly, and the computing correcting mechanism. The right-hand rod, known as the thermometer rod, carries a thermometer to indicate the existing temperature. The thermometer is graduated from 0° to 40°C.

(4) *Barometer Tube Assembly.* The barometer tube assembly consists of a glass barometer tube (fig. 1-2) with a gasket for sealing it to the base, and a tube seal valve assembly. The glass tube is the container for the mercury column and is made of precision bore pyrex tubing. The lower end connects to the cistern by means of the connecting passage in the barometer base. The upper end is closed off by the tube seal valve which is operated through a rubber diaphragm. The rubber diaphragm makes it possible to evacuate the area above the valve, which in turn makes it possible to develop a high vacuum above the mercury column in the tube, with an ordinary vacuum pump. An evacuation stem, protruding from the side of the tube above the valve, connects to the tube evacuation nipple with a short piece of rubber or plastic tubing.

(5) *Scale and Computing-Correcting Mechanism.* The scale and computing-correcting mechanism (figs. 1-3 and 1-4) consists of a vernier scale, a vernier slide assembly, a cam bar, a cam positioning assembly, and a temperature-gravity scale with its two indices. The scale is fastened to the left hand rod of the barometer frame. It has two sets of graduations, millimeters of mercury on the left hand or pressure side (pressure graduations) and thousands of feet on the right hand or altitude side (altitude graduations). Surrounding the scale and rod and sliding upon them is the vernier slide assembly. It carries the vernier scale, the altitude index, the applied correction scale, the sighting ring, the light assembly, and the correcting lever. A meniscus magnifier on a swivel bracket is also mounted on the front surface of the vernier slide assembly. The cam bar is pivoted at its lower end near the bottom of the scale. Its upper end is positioned by the cam positioning assembly, which tilts the cam bar to the left or right of vertical, depending upon the settings of the temperature and gravity indexes.



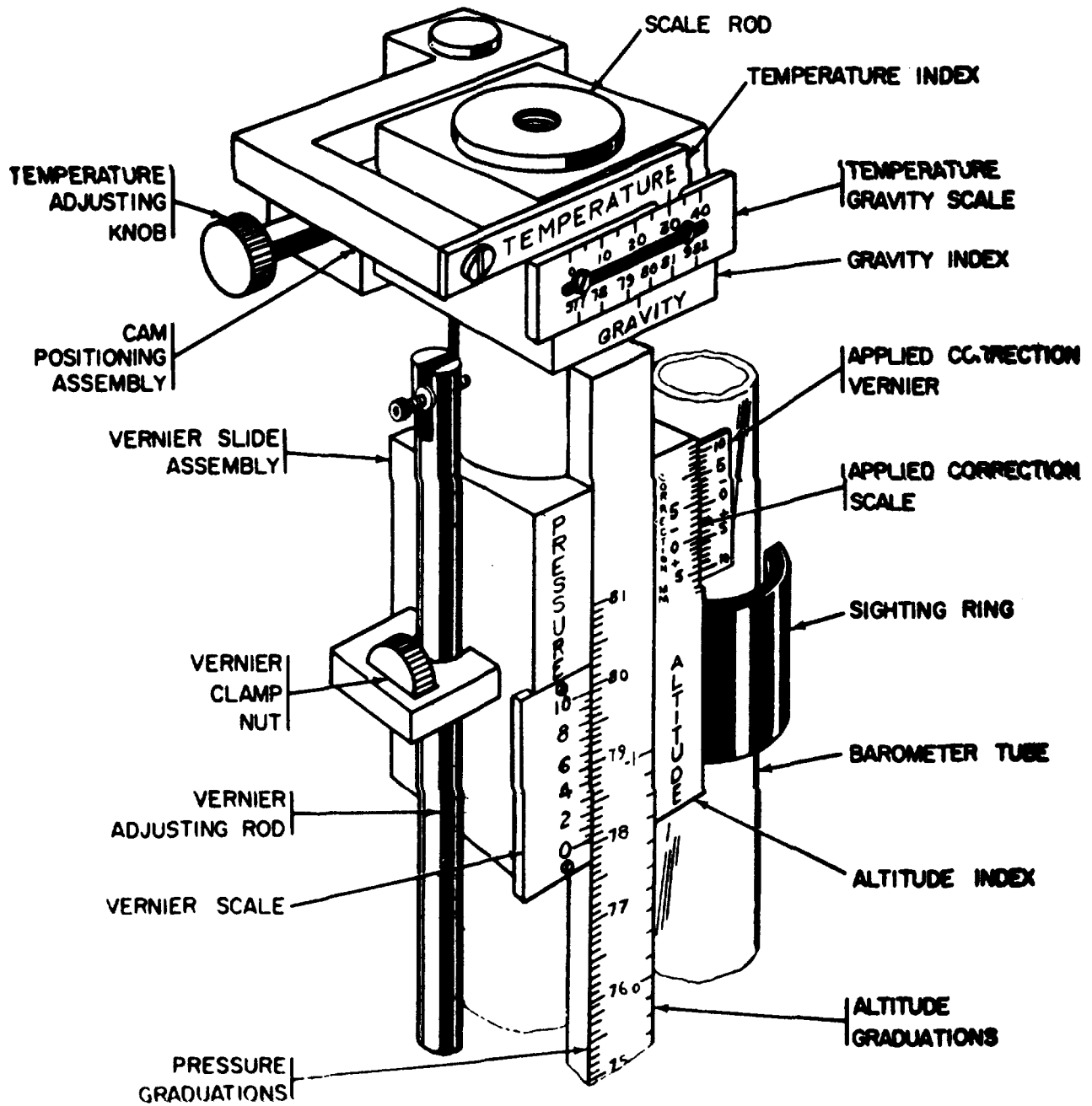

MI(C) 6685-202-14-1-3

Figure 1-3. Computing-correcting mechanism - front view.

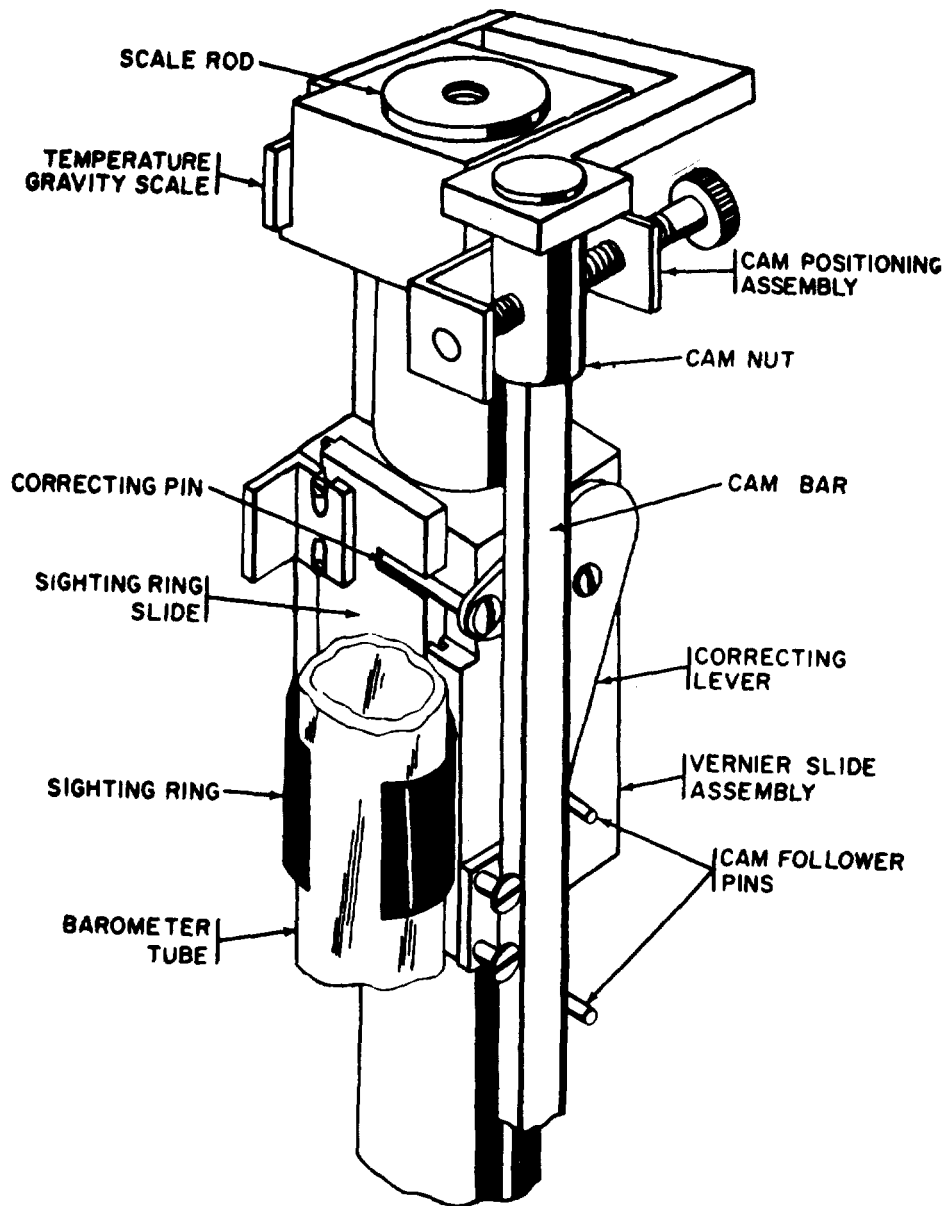

MI(C) 6685-202-14-1-4

Figure 1-4. Computing-correcting mechanism - rear view.

b. *Type A-1 (Modified).* The type A-1 modified barometer (fig. 1-1) consists of a precision bore glass tube rising out of a fixed cistern. The tube is supported by a frame set on a mounting platform. The cistern is also a precision bore glass cylinder and is mounted on the barometer base and connected to the tube through a passage in the base. The modified barometer has a micrometer mounted in the cistern to measure the level of mercury in the cistern. so, the modified barometer has a vacuum gauge and sensing

element, and an evacuation manifold and valve assembly. The various components that comprise the modified barometer are located and identified in figure 1-2.

(1) *Mounting Platform Assembly.* The mounting platform (fig. 1-2) serves as a level platform for mounting the barometer proper. Two sensitive bubble levels and three leveling strews are provided. One division of the level scales equals 30 seconds of arc. A battery compartment

and a pushbutton switch for the light are also included.

(2) *Cistern and Base Assembly.* The mounting platform (fig. 1-2) consists of a stainless steel base on which is mounted the cistern, the barometer base, the barometer tube, and the gage block mount. The cistern is a precision bore pyrex cylinder. The barometer base incorporates a connecting passage between the cistern and the barometer tube. The cistern is pressure sealed with gaskets to the base on the lower end and to a cistern lid at the upper end. The lid incorporates a cistern nipple and gasket for connecting the barometer to a pneumatic system under test, and a micrometer for measuring the mercury level in the cistern. The barometer base is fastened to the mounting platform by two hexagon socket head screws which thread into tapped holes in the platform assembly.

(3) *Barometer Frame Assembly.* The frame assembly is composed of two 7/8 inch diameter rods mounted vertically on the barometer base, (fig. 1-2) on either side of the barometer tube. The upper end of each rod is fastened to a top mounting disc which also provides support for the upper end of the barometer tube. The lefthand rod, known as the scale rod, carries the scale and vernier slide assembly. The right-hand rod, known as the thermometer rod, carries a thermometer to indicate the existing temperature. The thermometer is graduated from 0° to 40° C.

(4) *Barometer Tube Assembly.* The barometer tube assembly consists of a glass barometer tube (fig. 1-2) with a gasket for sealing it to the base. The glass tube is the container for the mercury column and is made of precision bore pyrex tubing. The lower end connects to the cistern by means of the connecting passage in the barometer base.

(5) *Vacuum Gage Assembly.* The vacuum gage assembly consists of an electrical meter, driven by a thermoconductivity type sensor element. The sensor element is connected to the evacuation manifold and monitors the vacuum above the mercury column continuously.

**1-8. Tabulated Data**

a. *Barometer Data.* Table 1-1 contains the data on dimensions, weight, and performance capabilities and limitations of the type A-1 barometer and the metric mercurial barometer type A-1 (modified).

b. *Auxiliary Equipment Data.* Table 1-2 contains the data on dimensions and performance characteristics of the rotary vacuum pumps and constant vacuum regulator used with the barometers as auxiliary equipment.

**Table 1-1. Barometer Data  
Type A-1 (Unmodified)**

DATA	VALUE
Physical Data	
Cubic contents crated without spares.	21.3 cu feet
Weight without equipment spares	
Weight, empty	34 lbs
Weight with mercury	40.5 lbs
Weight of mercury	6.5 lbs
Overall dimensions	
Height	42.5 inches
Width of base	10.5 inches x 10.5 inches
Crated dimensions	22 x 24 x 70 inches

<sup>1</sup> See footnote at end of table.

**Table 1-1. Barometer Data  
Type A-1 (Unmodified) - Continued**

DATA	VALUE
Capabilities and Limitations	
Calibration range	-1000 feet to 200,000 ft altitude.
Atmospheric and pneumatic pressure	0 to 790 mm Hg abs
Accuracy without charts <sup>1</sup>	± 0.2 mm Hg
Accuracy with calibration chart 1	
In terms of mercury column	Less than ± 0.1 mm Hg (equivalent to 3.5 ft at sea level or 0.00193 psi).
In terms of barometric pressure	Within 0.015 percent of full scale.
Sensitivity	0.05 mm visual scanning, using vernier.
Computing - compensating device correction range.	
Temperature value	0° to 40° (32° to 104°F)
Gravity value	977 to 982 cm/sec 3
Finest degree of correction	0.10 mm Hg
Battery utilized	Two BA-30, type C, dry cells.
Thermometer range	0° to 40°C (32° to 104°F)
Thermometer accuracy	± 0.05°C (after calibration)

<sup>1</sup> Manufacturer's specifications.

**Type A-1 (Modified)**

DATA	VALUE
Physical Data	
Cubic contents crated, without spares.	21.3 cu feet
Weight without equipment spares	
Weight, empty	39 lbs
Weight, with mercury	45.5 lbs
Weight of mercury	6.5 lbs
Overall Dimensions	
Height	42.5 inches
Width of base	10.5 x 10.5 inches
Crated Dimensions	22 x 24 x 70 inches
Capabilities and Limitations	
Pressure range	0 to 790 mm Hg abs and differential
Accuracy	± .014% of reading ± .092 mm Hg.

**Table 1-1. Barometer Data  
Type A-1 (Modified) - Continued**

DATA	VALUE
Scale	0 to 820 mm Hg
Scale accuracy	±.0015 inches (.04 mm)
Micrometer range	0 to 1 inch (0-25.4 mm)
	± .0004 inche.
Micrometer accuracy	.01 mm
Thermometer range	0° to 40°C (32° to 104°F)
Thermometer accuracy	± 0.05°C (after calibration)
Vacuum gage range	0 to 100 millitorr and 0 to atm
Vacuum gage accuracy	+ 10% (after calibration)

**Table 1-2. Auxiliary Equipment Data**

DATA	VALUE
Rotary Vacuum Pump (4310-203-3057)	
Length	17.5 inches
Height	14.375 inches
Width	10.3125 inches
Speed	600 rpm
Free air displacement	21 liters/minute
Guaranteed vacuum	0.1 micron Hg
Motor power requirements	115/230 vac, 60 cycles, single phase, 1/3 hp.
Motor full load rating @	
115 volts	5.6 amps
230 volts	2.8 amps
Motor fuse rating, maximum @	
115 volts	20 amps
230 volts	15 amps
Rotary Vacuum Pump (4931-92-8403)	
Length	17.125 inches
Height	10.50 inches
Width	12.625 inches
Speed	450 rpm
Free air displacement	21 liters/minute
Guaranteed vacuum	0.1 micron Hg
Motor power requirements	115 vac, 60 cycles, single phase, 1/3 hp.
Motor full load rating @ 115 volts	5.6 amps
Motor fuse rating, max @ 115 volts	20 amps

Table 1-2. Auxiliary Equipment Data- Continued

DATA	VALUE
Constant Vacuum Regulator Length Width Height Range, absolute pressure Weight	5.875 inches 4.375 inches 13.875 inches 3 to 60 in. Hg (adjust- able to 0.01 in. Hg). 16.25 lbs

## CHAPTER 2

## THEORY OF OPERATION

## Section I. GENERAL OPERATION

## 2-1. Fundamental Principles

a. *Basic Principle.* The basic principle of the type A-1 barometer is similar to that of any standard mercurial barometer. The atmospheric or pneumatic pressure applied to the surface of the mercury in a cistern is automatically balanced by the weight of a vertical column of mercury enclosed in a glass tube. The space above the mercury in the glass tube is evacuated to minimize any force opposing the pressure being measured, other than the force produced by weight of the column of mercury. Since the weight of a column of mercury of uniform cross section varies directly as its length, the magnitude of the pressure applied to the cistern may be measured in terms of length (usually referred to as the height) of the column of mercury required to balance it. The height corresponding to normal atmospheric pressure at sea level is 760 millimeters of mercury, or 29.922 inches of mercury or 1013.3 millibars.

b. *Inherent Limitations of a Barometer.* It is evident that as the mercury column expands due to an increase in temperature, the length of a column of given weight will increase. The same is true for a decrease of gravitational force. Part of the error caused by the temperature expansion is canceled because the scale used to measure the height of the mercury column also expands. The two effects are not equal however, and a net temperature error remains. Therefore, if the height of the mercury column is to be a true measure of the pneumatic pressure, the observed readings must be corrected to the values which would exist if the readings were taken with the barometer maintained at a constant standard temperature and standard gravity. Zero degrees Centigrade (32° F) is universally adopted as the standard temperature. Standard gravity is expressed in

terms of acceleration (centimeters per second per second). The numerical value of standard gravity is 980.665. The magnitude of the temperature and gravity errors at any given reading depends on the deviation from standard temperature and standard gravity, and on the observed height of the mercury column. The errors, therefore, increase in magnitude as the length of the mercury column increases.

c. *Compensation Features*

(1) The type A-1 barometer has a computing-correcting mechanism which applies compensation for temperature and gravity errors when the temperature and gravity indexes are set for the existing conditions. The mechanism compensates for any temperature from 0° to 40° C (32° to 104° F), and for any value of gravity from 977 to 982 cm/sec<sup>2</sup>. The accuracy of the compensation limits the accuracy of the barometer readings. Applicable specifications call for the temperature and gravity compensation to be correct to within 0.10 mm of mercury. The scale, therefore, indicates true pressure as reduced to standard conditions.

(2) The modified barometer does not have a computing-correcting mechanism. A true-length, more finely divided scale; a precision micrometer; and a vacuum gage have been added to the modified barometer. By substituting the values indicated on the scale and micrometer along with local values of gravity and temperature and standard values of gravity and temperature into an equation, the errors normally associated with mechanical corrective devices is eliminated.

## Section II. FUNCTIONAL DESCRIPTION

## 2-2. General

a. *Type A-1.* The barometer is designed

for use as a standard for calibrating altimeters in the range of -1000 feet to + 80,000 feet. The barometer accurately measures atmospheric and pneumatic pressures from zero to 790 millimeters (mm) of mercury absolute. The barometer is accurate within  $\pm 0.2$  mm of mercury without the use of charts. Using a calibration chart, the tolerance is less than  $\pm 0.1$  mm, equivalent to 3.5 feet at sea level. The accuracy is within 0.0015 percent of full scale in terms of barometric pressure. The barometer is equipped with a compensating system which automatically computes and applies corrections for deviations from standard temperature and gravity. It is also possible to check the functioning of the barometer at all points where error could be introduced. For checking the level of mercury in the system or checking the corrections for temperature and gravity by comparison with the computed values, see paragraph 4-5.

*b. Type A-1 (Modified).* The modified barometer is designed for use as a standard for calibrating barometers and other pressure measuring devices with the same or lesser accuracy. The barometer accurately measures atmospheric and pneumatic pressures from zero to 790 millimeters of mercury absolute and differential. The barometer is accurate within  $\pm 0.014\%$  of reading  $+0.092$  millimeters of mercury (torr).

#### NOTE

**The main scale is graduated to 820 mm. However, due to mechanical limitations the slide will only move to 790 mm.**

### 2-3. Mercury Column and Vernier Scale (All Models)

The height of the mercury column is read by means of the sighting ring, scale, and scale index or vernier scale (fig. 1-2). The scale is parallel and adjacent to the mercury column. The sighting ring surrounds the column and is mounted on the vernier slide assembly which slides along the scale. The vernier scale is also part of the vernier slide assembly and is used to read the position of the slide assembly on the scale. The height of the column of mercury is read by positioning the lower edge of the sighting ring even with the highest point of the mercury column. The

position of the vernier slide assembly along the scale is then read by means of the scale index. Refer to paragraphs 3-9 and 3-10 for sighting the mercury level and reading the scale and vernier.

### 2-4. Computing-Correcting Mechanism (Type A-1 Only)

When the temperature and gravity indexes are aligned for standard conditions, the cam bar is in a vertical position. When the indexes are set to nonstandard conditions, the upper end of the cam bar is displaced to the right or left of vertical depending on the direction of the deviation from standard conditions. The displacement of the upper end will cause a displacement all along the bar which will be proportional at any point to the distance of that point from the lower end of the bar which is pivoted. The magnitude of the displacement of the upper end is proportional to the magnitude of the deviation from standard temperature and gravity as set on the temperature and gravity scales. The displacement from the vertical at any point along the cam bar will be proportional to the deviation of the temperature index from 25°C; the deviation of the gravity index from 980.665 cm/sec<sup>2</sup>; and the height of the mercury column represented by the distance along the cam bar from its pivoted end. Since the temperature and gravity errors of the barometer are also proportional to these same factors, the displacement of the cam bar from the vertical at any point is a measure of the temperature and gravity errors of the barometer at that point. Thus the errors have been computed by the cam bar and translated in terms of horizontal displacement.

### 2-5. Application of Corrections (Type A-1 Only)

The horizontal displacement of the cam bar is detected by the correcting lever whose pivot is on the vernier slide assembly, and therefore, moves vertically with the slide. The correcting lever is similar to a bell crank, with two arms arranged at right angles, pivoting at the elbow. The cam follower pins are attached to the lower arm of the correcting lever and maintained in contact with the cam bar by a spring. The other arm of the correcting lever carries the correcting pin which engages the sight-



ing ring slide. These two arms at a 90 degree angle convert the horizontal displacement of the cam bar, which is proportional to the temperature and gravity errors at the point where the vernier slide is positioned, to a vertical displacement of the sighting ring slide. As explained in paragraph 2-3, moving the sighting ring with respect to the scale index will effectively increase or decrease the height of the mercury column as read on the scale. Thus the barometer reading is corrected for temperature and gravity errors and the scale reading is the true pressure as reduced to standard conditions.

## **2-6. Applied Correction Scale and Index (Type A-1 Only)**

A vernier strip is fastened to the sighting ring slide, which, when read against the applied correction scale on the vernier slide, indicates the direction and magnitude of the correction being applied. Its indication is used only in calibrating or checking the computing-correcting mechanism, and may be disregarded in the normal use of the barometer.

## CHAPTER 3

### OPERATING INSTRUCTIONS

#### Section I. SERVICE UPON RECEIPT OF MATERIEL

##### 3-1. Unpacking

The barometer is received in a wooden box with approximate dimensions of 22 by 24 by 70 inches. In order to protect the instrument during shipment, the vacuum in the mercury tube is released and the mercury locked in the cistern. The barometer is also removed from the mounting platform. Unpack the barometer as follows:

- a. With the box placed horizontally, remove the top.
- b. Remove coils of cellulose wadding.
- c. Lift out the inner box and mounting platform.
- d. Remove the 16 by 16-inch plywood squares at either end of the inner box.
- e. Withdraw screws securing lid and open inner box.
- f. Withdraw nails securing upper half of yoke, which retains barometer.
- g. Remove the two socket head screws securing base of barometer to end of box.

#### CAUTION

**Do not grasp the instrument by either the scale bar, the vernier slide assembly or the cam bar (see figure 1-2). Bending the cam bar a few thousandths of an inch is discernible as an error in instrument readings.**

- h. Open moistureproof bags and remove desiccant.
- i. Remove wax wrapping from the barometer.
- j. Unwrap the mounting platform.
- k. The barometer is not installed on the mounting platform until after it has been physically inspected and the mercury tube has been pumped free of moisture.

##### 3-2. Inspection

- a. *Mechanical Parts.* When a new or reconditioned barometer is received, it is the

responsibility of the officer in charge to determine whether the materiel has been properly prepared for service and if it is in condition to perform its assigned mission when placed in service. Inspect all major units, assemblies, subassemblies, and equipment to make sure that they are properly assembled, secure, clean, and correctly adjusted.

- (1) Check all spare parts, tools, and equipment to be sure every item is present, in good condition, clean, and properly mounted and stored.

- (2) Make a record of any missing parts and malfunctions. Correct any deficiencies as quickly as possible.

- (3) Special attention must be directed to the small parts as they are more likely to become lost. This may seriously affect the proper functioning of the materiel.

- (4) Whenever practicable, the operator will assist in the performance of these services.

- b. *Precision Instrumentation.* Determine that the delicate elements of the barometer have been unpacked without damage or distortion.

- (1) All switches and controls must function normally.

- (2) All vernier scales and other essential markings shall be legible.

- (3) The scale, scale rod, thermometer rod, and cam bar must not be bent or distorted. These items are straightened to within  $\pm 0.001$  inch and should be so maintained to retain maximum accuracy.

##### 3-3. Reporting Discrepancies

- a. Refer to paragraph 1-5 and appendix A for applicable forms, records and reports for inspection. An examination of the preventive maintenance records of the barometer will reveal its general maintenance background. A record of progressive repairs may indicate that the unit is in excellent condition. All cloth or paper tags attached to the materiel should be carefully noted and indicated. Verify the serial number of the materiel with the numbers recorded in the records of the using personnel.

### 3-4. Installation of Batteries

Batteries are not shipped with the instrument and should be procured by the using activity. Two BA-30, type C, dry cells, Federal stock number 6135-120-1020 (which fit a standard flashlight), are required.

a. Remove the battery screw (fig. 1-2) on the right-hand side of the mounting platform.

b. Insert the battery screw in the tapped hole in the end of the battery tube. Pull out the battery tube.

c. Insert the batteries into the tube with the center terminal of each battery pointed toward the closed end of the tube. Reinstall the battery tube in the mounting platform and lock it in place with the battery screw.

### 3-5. Preparation for Use

a. *Type A-1.* A power-driven rotary vacuum pump is supplied with the barometer to provide the barometer with a suitable vacuum source which will reduce the pressure to at least 100 millitorrs (0.1 mm).

See paragraph 3-7 for pump operation. To operate as a calibrating pressure measuring instrument, a controlled source of at least 20 pounds per square inch gage pressure is also required. The barometer achieves its best accuracy and ease of reading when installed in a well-lighted, well-ventilated, or air-conditioned room.

#### NOTE

**If possible, use clean or filtered air when operating the instrument to avoid contamination of the mercury or frequent clogging of the cistern nipple.**

The instrument should be placed at a point of minimum vibration, near a wall or supporting column allowing at least 10 square feet of floor space. A sturdy table about 30 inches high is desirable.

#### NOTE

**It is not necessary to fill the barometer with mercury on delivery from the manufacturer since it is already filled and the mercury locked in the cistern by the mercury locking screw. If required, fill the barometer in accordance with the instructions specified in paragraph 4-5b.**

(1) *Removal of Moisture.* To remove traces of moisture which may have entered the barometer tube during shipment, proceed as follows:

(a) Using a sturdy table, tilt the barometer over backwards (cistern side down) until the tube and scale are approximately horizontal. Support the top of the barometer to maintain this position. The cistern will be below the tube and slightly more than half full of mercury. The mercury locking screw will be visible in the bottom of the cistern.

(b) Remove the off-center hexagonal head shipping plug nearest the mercury tube in the cistern lid.

(c) Insert a clean screwdriver through the shipping plug hole and unscrew the mercury locking screw in the bottom of the cistern (fig. 3-1) until it is stopped by the small shouldered stop screw at its edge. This valve is left open and is closed only when sealing mercury in the cistern for shipment.

#### CAUTION

**Do not remove the small shouldered stop screw or the mercury locking screw.**

(d) Replace the shipping plug with the cistern nipple (fig. 1-2), making sure there is no dirt on the cistern lid or nipple gasket.

#### NOTE

**Be sure to install the nipple gasket or the cistern will leak.**

(e) Tighten the cistern nipple securely with approximately 30 pounds pull on an eight-inch wrench. Clamp off the end of the rubber tubing connected to the nipple with the clamp provided.

(f) Connect a tube from the vacuum pump to the tube-evacuation nipple (fig. 1-2). With the cistern nipple tube clamped off, start the vacuum pump and open the tube seal valve by turning the tube seal knob (fig. 1-2) clockwise as viewed from the top of the barometer. This lifts the ball valve from its seat inside the glass tube. If the barometer is being set up after shipment or storage, allow the pump to evacuate the tube and cistern for at least two hours before proceeding to the next step. This will remove any traces of moisture which may have gotten into the tube during shipment or storage.

(2) *Preliminary Adjustments.* When all traces of moisture have been removed from the barometer tube, perform the following preliminary adjustments to prepare the barometer for use:

(a) While the pump is running, move the barometer so that the bottom of the base is even with the edge of the table.

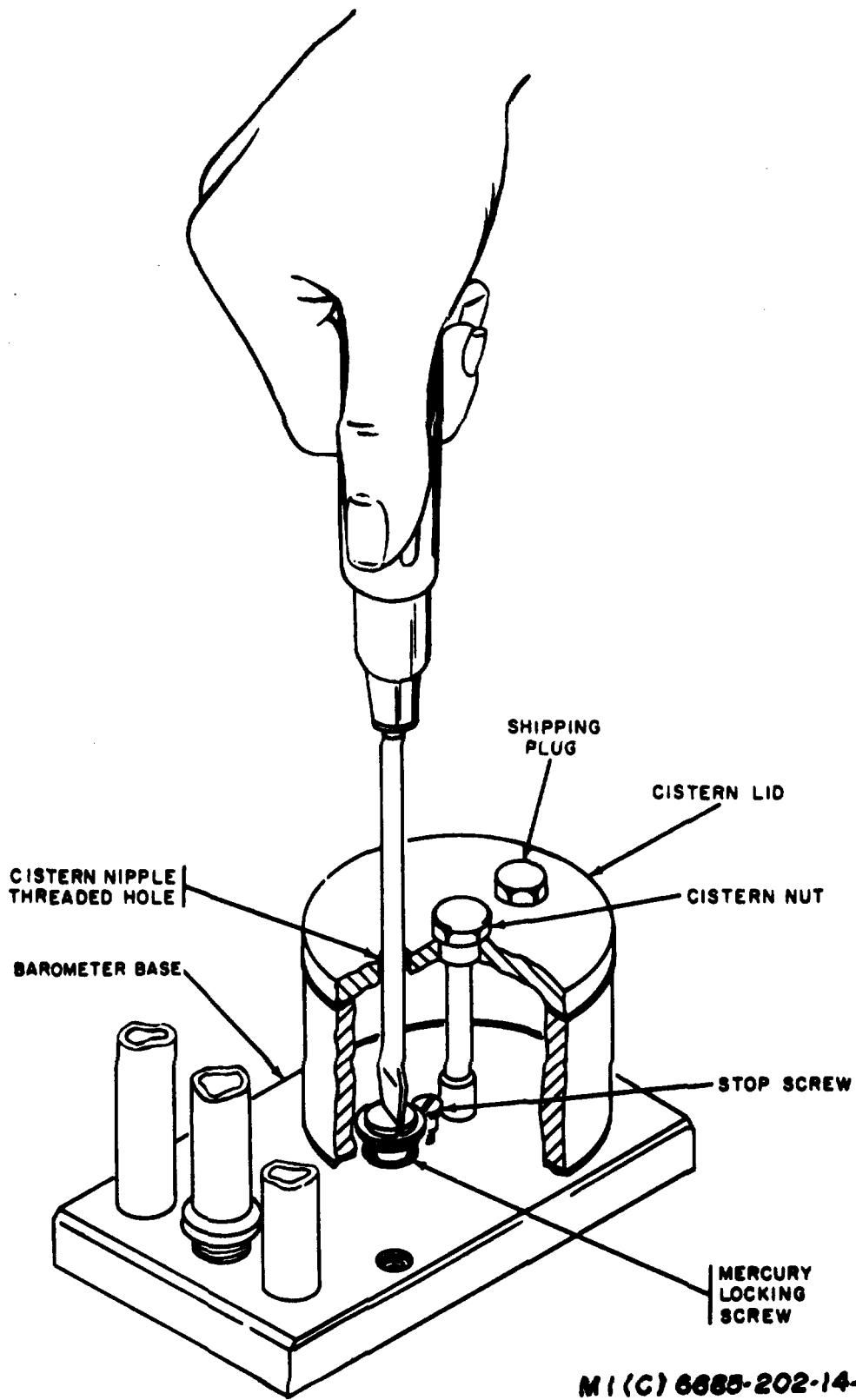

Figure 3-1. Mercury locking - screw adjustment.

Fasten the mounting platform to the barometer by inserting the two 5/16-24 socket head screws through the holes in the barometer base assembly and into the tapped holes in the platform assembly.

(b) With the pump still running at the end of two hours, return the entire instrument to its normal vertical position. The mercury will rise in the barometer tube to the same level as in the cistern.

(c) Slowly open the clamp on the tube connected to the cistern nipple. This will allow the mercury to rise in the barometer tube until it attains a level depending upon the existing atmospheric pressure.

(d) Connect hand blower 6640-5104-521 (found in the mounting platform drawer) to the cistern nipple and pump air into the cistern until the mercury in the barometer tube rises to the level of the orange calibration line etched into the tube (visible through the cut-out in the top of the barometer). Close the tube seal valve by unscrewing tube seal knob at the top of the barometer. Remove the hand blower, and the mercury will fall to the atmospheric pressure level. Remove the vacuum pump from the tube-evacuation nipple. Install the meniscus magnifier on the post of the sighting ring slide.

(e) Level the mounting platform by means of the three leveling screws, using the indication of the two levels in the mount platform. Clockwise rotation of the leveling screws raises the platform.

#### NOTE

**The instrument must be maintained level within 30 seconds of arc to reduce leveling errors to below 0.02 mm of mercury. This is done by centering the bubbles within one division on the level scales.**

(f) Loosen the two screws which hold the temperature-gravity scale (fig. 1-3) and slide it to align the GRAVITY index with the value of gravity at the location of the barometer. If the latitude and elevation are known, the value of gravity can be determined in accordance with instructions in paragraph 3-5 a(3). Tighten the two screws securely. Once properly set, the gravity index is not changed unless the barometer is shipped to another location.

(g) Align the temperature index to the existing temperature, as indicated by the thermometer, by rotating the temperature adjusting knob (fig. 1-3). A

clockwise rotation moves the temperature index toward a lower temperature, while a counterclockwise rotation raises it. With the temperature and gravity indexes properly set, the reading of all models of the barometer will be true pressure, reduced to standard temperature (25°C) and standard gravity (980.665) cm/sec<sup>2</sup>. The barometer is now ready for operation.

#### (3) Gravity Adjustment and Correction Chart.

The purpose of the gravity adjustment is to set the correct gravity correction for the location at which the instrument is used. The proper value of gravity to be used in making the setting is sometimes specified for the station at which the instrument is used. If the value is not available, obtain it from the gravity correction chart, figure 3-2, which is a plot of the values of gravity against latitude. Since gravity varies with elevation, several curves are given, each representing a different elevation. The elevation is marked on the curve for sea level, 5,000 feet, and 10,000 feet; with intermediate curves for each 1,000 feet elevation. Values of latitude are found at the bottom of the chart, and values of gravity are found at the left of the chart. To use the chart, the latitude and elevation must be known. Find the latitude at the bottom of the chart. Follow a vertical line until it intersects the proper elevation line. Then follow the horizontal line to the left to read the value of gravity to which the gravity index should be set.

*b. Type A-1 (Modified).* A power-driven rotary vacuum pump and a thermoconductivity-type vacuum gage are supplied with the modified barometer. See paragraph 3-7 for pump operation. The barometer achieves its best accuracy and ease of reading when installed in a well-lighted, well-ventilated, or air-conditioned room. The instrument should be placed at a point of minimum vibration near a wall or supporting column, allowing at least 10 square feet of floor space. A sturdy table about 30 inches high is desirable.

#### NOTE

**If required, fill the barometer in accordance with paragraph 4-5b.**

(1) *Removal of Moisture.* To remove traces of moisture which may have entered the barometer tube during shipment, proceed as follows:

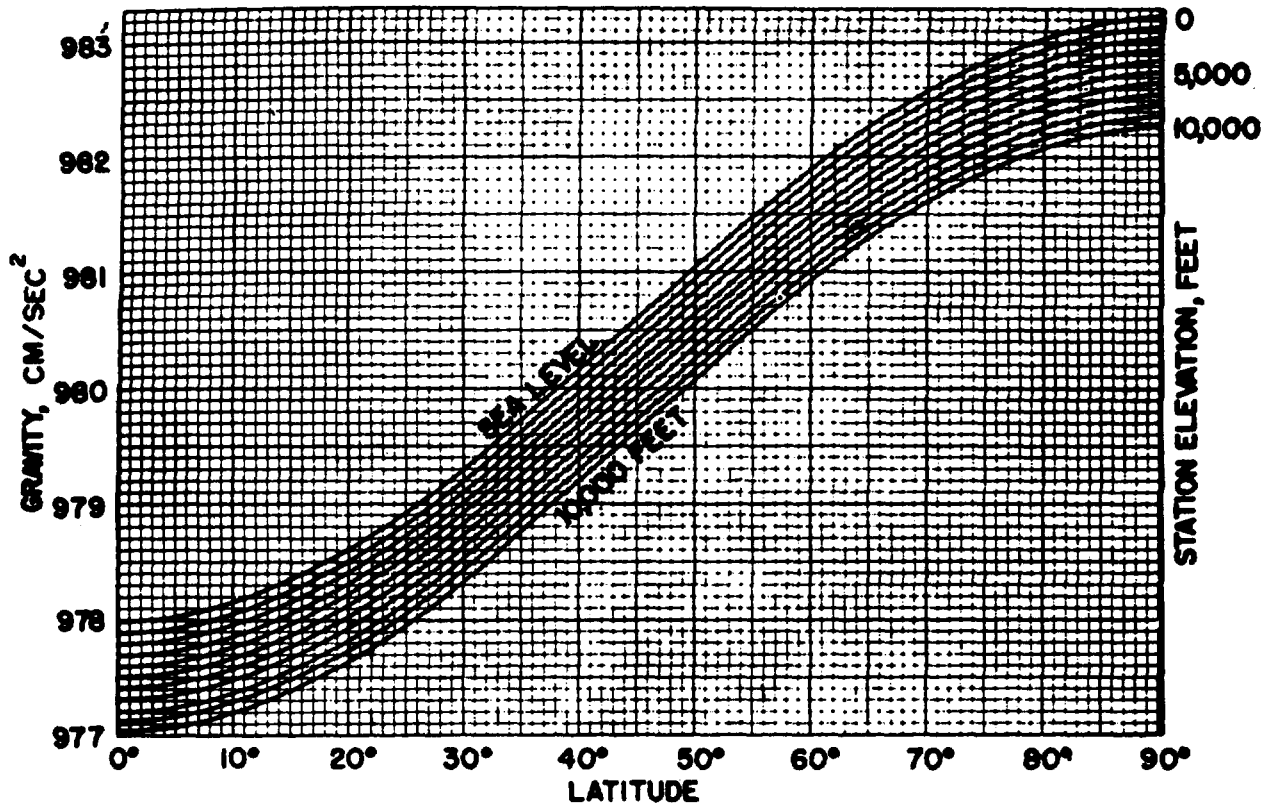

Figure 3-2. Gravity correction chart.

(a) Remove the off-center hexagonal-head shipping plug and replace with cistern nipple (fig. 3-1).

**NOTE**

**Be sure to install the nipple gasket.**

(b) Tighten the cistern nipple securely with approximately 30 pounds on an eight-inch wrench.

(c) Install tubing, fittings, valves, and vacuum gage sensor as shown in figure 1-1.

(d) Connect a tube from the cistern nipple to the vacuum line connection nearest the cistern. Close valve to cistern.

(e) Connect a tube from the vacuum pump to the barometer evacuation connection.

(f) Operate vacuum pump until 50 microns is indicated on the vacuum gage. This will remove any traces of moisture which may have gotten into the tube and cistern during shipment and storage.

(2) *Preliminary Adjustments.* When the vacuum gage indicates 50 microns, perform the

following preliminary adjustments to prepare the barometer for use:

(a) Level the mounting platform by means of the three leveling screws, using the indication of the two levels in the mount platform. Clockwise rotation of the leveling screws raises the platform.

**NOTE**

**The instrument must be maintained level within 30 seconds of arc to reduce alignment errors to below 0.02 mm of mercury. This is done by centering the bubbles within one division on the level scales.**

(b) Deenergize vacuum pump and carefully open both the tube and cistern to atmospheric pressure.

(c) Install mercury under vacuum as described in paragraph 4-5b.

(d) Loosen the set screw at the base of the micrometer barrel and rotate barrel until index line is at a convenient position

for reading. Tighten set screw.

(e) Set micrometer to zero reading.

(f) Loosen shaft set screw and move shaft until slight "dimple" can be seen on the mercury surface. Tighten the set screw.

(g) Check reading and reset if necessary.

(h) The barometer is now ready for operation.

## Section II. OPERATION UNDER USUAL CONDITIONS

### 3-6. Controls

a. The barometer contains no controls that must be set prior to operation.

b. This section describes the procedure for normal operation of the barometer. It is assumed that the instrument is free from maintenance problems as ascertained in the inspection procedures in paragraph 3-2. This section also includes the operation of the vacuum pump and constant pressure regulator, which although not part of the barometer, are essential to its operation.

### 3-7. Operation of Vacuum Pump 4310-2033057 or 4931-929-8403

a. The vacuum pump is a motor-driven, rotary-type, oil-sealed pump operating on the principle of the eccentric rotor with spring operated moving vanes. Air at atmospheric pressure is forced into a smaller volume by the action of an eccentric rotor with moving vanes always in contact, and is expelled from the exhaust port. The pump is a two-stage, series connected type. The two stages, intake and exhaust, have equal volumetric displacement. A single spring actuates each valve. The entire pump mechanism is immersed in a bath of oil which insures a tight vacuum seal of the stages, acts as a coolant, and lubricates the moving parts. The pump and motor are mounted on a steel base.

b. To operate the vacuum pump, proceed as follows: (1) Connect the motor to a power source of the voltage, frequency and phase indicated on the nameplate of the motor, normally 115 volts, 60 cycles, single phase.

#### CAUTION

**The power line would be heavy enough to carry the current required without an undue drop in voltage. Fuses provide short circuit protection only for the power supply line and do not protect the motor**

**from overload. It is recommended that a suitable motor starting switch with motor overload protection be used for all permanent installations. The motor is supplied with a connecting cord and plug for operation on 115 volts. For operation on 230 volts rewire as shown on inside of the cover of the motor connection box.**

(2) The oil is drained from the pump for shipment. A gallon of Cenco No. 93050 vacuum pump oil is supplied with each pump. Approximately three quarts are needed in the pump. To fill the pump, remove the top cover and fill with the oil supplied until it is slightly above the oil level as indicated in the window on one side of the pump. In operation, the oil should be even with, or slightly above, the oil level as indicated in the window.

#### NOTE

**The 4931-929-8403 pump is shipped with on quart of Cenco No. 9050 vacuum pump oil and is filled through the exhaust port.**

#### CAUTION

**Measure the oil carefully. If insufficient oil is used, a good seal around the vane may not be maintained. If too much oil is used, oil may back up through the pump trap into the vacuum line.**

(3) When the oil has become contaminated, as can be seen through the inspection window, drain the pump, flush with a small amount of vacuum pump oil and refill with Cenco vacuum pump oil No. 93050, Federal Stock Number 9150-273-8663. Most of the oil may be drained through the drain cock.

To completely remove all oil, invert the pump and turn the shaft several revolutions to flush out any remaining oil.

### CAUTION

**Do not use solvents or light flushing oils. Their complete removal is difficult and their high vapor pressures will prevent the attainment of a high vacuum.**

(4) If the oil has thickened or contains sludge, it is advisable to remove the oil reservoir case and thoroughly clean the case with lint-free rags. Varnish a new gasket and install it on the case. Tighten all screws uniformly. Also replace the shaft seal.

(5) The frequency of oil change depends upon the service or use of the pump. If the pump is operating against a vaporless dustless system, change oil once every six months; if vapors pass through the pump in any quantity, a daily change of oil may be needed.

(6) During shipment, the intake nipple of the vacuum pump is closed to prevent entrance of foreign matter into the pump. In handling the pump, similar precautions should be exercised. In connecting the pump to the system to be evacuated, extreme care must be taken to eliminate leakage. All connections should be as short as possible, and of large diameter. When the pump is operating in the low micron range, the flow of gas through a tube is substantially molecular in character. At low pressures, the gas removed from the system is confined largely to those molecules which because of their kinetic energy of agitation, happen to hit the intake of the pump when the cylinder of the pump is open to the intake.

(7) If metal piping is used, it is the best practice to solder or braze all connections. When threaded pipe joints must be used, the threads should be as nearly perfect as possible. In such a connection, screw the members together several turns, and then apply black glyptal to the exposed threads before screwing together tightly. Allow the glyptal to dry several hours before starting the pump. If flanged connections are used, flat or o-ring gaskets made of rubber or neoprene should be used between the parts to reduce leakage. Place a thin coat of vacuum stopcock grease on the o-ring before using.

(8) When standard tapered or ball and TM 9-6685-202-14 socket joints are used in connections, a vacuum stopcock grease should be used on both members.

(9) Rubber tubing connections should be kept as short as possible and made with an extra heavy wall, gum tubing, which has been compounded specially for vacuum work. All connections to metal or glass tubing should fit snugly and both members should be coated with vacuum stopcock grease. Tygon tubing is adequate for most applications.

(10) Metal vacuum valves and glass stopcocks are employed generally in the connecting line between the pump and the system to provide a means of connecting the vacuum gage and for vacuum release when stopping the pumping.

### CAUTION

**Take care to prevent solid particles from reaching the pump intake. Particles can score the working parts of the pump and reduce its efficiency. If corrosive vapors or large amounts of water vapor are in the system, use a freezing trap in the line to prevent them from entering the pump and to keep pump oil vapor from entering the system. Use a mixture of dry ice and acetone or ethyl alcohol as a vacuum flask refrigerant.**

### 3-8. Operation of Constant Vacuum Regulator 6685-306-5604

a. The constant vacuum regulator is a hand set device which maintains set pressures within close limits over extended periods. The regulator is suitable for both vacuum and pressure systems for calibrating and testing pressure sensitive instruments and for controlling vacuum apparatus. The regulator is continuously adjustable over the entire range by a handwheel. No external reference pressure is required.

#### KEY to fig. 3-3.

1. Adjusting handwheel
2. Control spring
3. Spring and bellows connector
4. Vacuum throttling valve
5. Vacuum pump connection
6. Test connection
7. Bellows
8. Air inlet
9. Air filter
10. Valve port
11. Valve disc
12. Adjusting screw



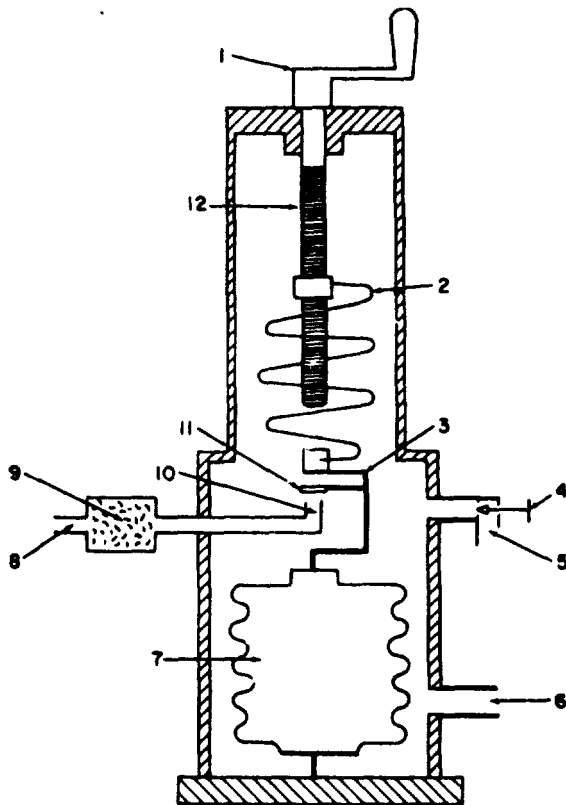

MI(C) 6685-202-14-3-3

Figure 3-3.

Constant vacuum regulator - operated wider vacuum.

**NOTE**

The numbers in parenthesis shown below refer to figure 3-3.

b. The operation of the constant vacuum regulator is schematically shown in figure 3-3. The source of vacuum is connected to the vacuum pump connection (5). The vacuum test chamber, barometer, or apparatus where control of vacuum is desired is connected to the test connection (6). Vacuum throttling valve (4) is opened and adjusted to suit the capacity of the vacuum pump. Air inlet (8) with air filter (9) is left open to atmospheric pressure. When adjusting handwheel (1) is turned clockwise, adjusting screw (12) stretches control spring (2). The spring tension is transmitted to bellows (7) by spring and bellows connector (3). Valve disc (11) is positioned over valve port (10) by spring and bellows connector (3), and valve disc (11) moves away from valve port (10) as the bellows (7) expands, and toward valve port (10) when the bellows contracts, thereby controlling the flow of air through the regulator.

c. If the vacuum test chamber is to be maintained at 15 inches of mercury absolute pressure, the handwheel is adjusted until the desired pressure is indicated on a manometer or indicator connected into the system. Turning handwheel (1) clockwise increases the absolute pressure and counterclockwise decreases the absolute pressure. When operating at 15 inches of mercury absolute pressure, the net resultant force of the bellows and spring equals that applied by a pressure of 15 inches of mercury absolute, and just sufficient air passes through port (10) to maintain equilibrium. If the pumping rate of the source of vacuum or the atmospheric pressure changes, the bellows immediately reacts and throttles the air inlet so that equilibrium is maintained.

d. In order to use the regulator on a pressure system, connect the pressure source to air inlet (8) and the pressure test chamber to test connection (6). Vacuum throttling valve (4) is cracked and allowed to vent to atmospheric pressure.

**CAUTION**

Take care when approaching the limits of the operating range so that the regulator is not forced past the internal stops. As soon as the crank wheel assembly binds, stop turning the handle. If it binds at any point other than the limit of the operating range, (3 to 60 inches of mercury absolute pressure) disassemble the regulator as described in paragraph 4-12m and inspect the operating mechanism.

**3-9. Operating Instructions**

a. *General.* Correct sighting of the mercury level and reading of the barometer scale must be thoroughly understood prior to using the barometer. These operations are explained in this section and are used in all applications of the barometer. These applications include operating the instrument as a barometer, to calibrate altimeters, as a gage-pressure manometer, as a differential-pressure manometer, and as an absolute-pressure manometer. The procedures for checking the level of mercury in the barometer and for removing an air bubble from the tube are also included.

b. *Sighting the Mercury Level.* Proper sighting of the mercury level is essential for accurate and consistent readings. Proceed as follows:

**NOTE**

Rapping the table before each reading will aid in adjusting the meniscus shape in the tube and cistern. The error incurred by improper meniscus shape may be as large as 0.15 mm.

(1) Unlock the vernier clamp nut and adjust the vernier slide assembly so that the lower edge of the sighting ring is approximately in line with the top of the mercury column.

(2) Lock vernier clamp nut and make the final adjustment with the vernier adjusting knob (fig. 1-2).

(3) When sighting the meniscus, use the barometers light to provide an illuminated background.

(4) Move the eye up and down to be sure it is aligned with both the front and rear edges of the sighting ring. Correct alignment is achieved at the point where the greatest amount of light is visible behind the meniscus. At the correct position of sighting ring and eye, the two edges of the sighting ring and meniscus will appear to just touch as in figure 3-4.

**CORRECT SETTING**

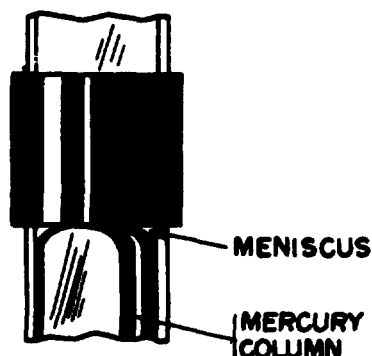

**NO LIGHT VISIBLE AT VERY CENTER ONLY**

**INCORRECT SETTING**

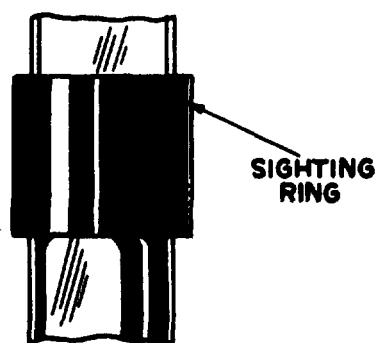

**SIGHTING RING LOW**



**SIGHTING RING HIGH**

Figure 3-4. Sighting the mercury level.

c. Constant Value of Units Table 3-1

lists constant values of units of measurement used in manufacturing and utilizing mercury barometers.

Table 3-1. Constants Used in Construction and Calibration of Mercurial Barometers.

DATA	VALUE
1 mm of mercury	0.019337 psi
1 mm	$10^{-1}$ cm - $10^{-3}$ m
1 mm	0.039370079 in.
1 in.	25.4 mm . 2.54 cm
1 mb	$10^3$ dynes $\text{cm}^{-2}$
1 mm	1 torr
1 micron	1 millitorr

**Table 3-1. Constants Used in Construction and Calibration of Mercurial Barometers - Continued.**

DATA	VALUE
1 mb	0.75006 mm of mercury at 0°C and standard gravity.
1 mm of mercury at 0°C and standard gravity.	1.3332 mb
1 mb	0.029530 in. of mercury at 0°C and standard gravity.
1 in. of mercury at 0°C and standard gravity.	33.864 mb
Density of clean mercury at 0°C	Assumed to be 13.5951 grams per cubic centimeter at pressure of one atmosphere.
Standard gravity	980.665 cm per second per second.
1 Standard atmosphere	1013.250 mb, 760 mm Hg (standard), 29.9213 in. Hg (standard), 14.6960 psi.
mm = millimeter(s) in. = inch(es) psi = pounds per square inch.	cm = centimeter(s) mb = millibar(s) m = meter(s)  C = Celsius (Centigrade).

**3-10. Reading the Barometer Scale**

*a. Type A-1*

(1) The left side of the scale is calibrated in millimeters of mercury from 0 to 790. The right side of the scale is calibrated in thousands of feet altitude from -1,000 to +80,000 feet. The applied correction scale is calibrated in millimeters. The temperature-gravity scale is calibrated in degrees centigrade and cm/sec<sup>2</sup>. The altitude scale is used in calibrating altimeters and is described in paragraph 3-13. On the millimeter scale, figure 3-5, only every tenth line is numbered and the final zero is omitted. Thus the 630 mm line is numbered 63. The number of whole millimeters is read at the last line on the main scale which the 0 line on the vernier scale has passed. The main scale is read from bottom to top. Thus in figure 3-5, the 0 line is slightly above 632 on the main scale.

(2) The number of tenths of a millimeter, in addition to the number of whole millimeters, is found by looking along the vernier scale and noting which line of the vernier scale is aligned with a line on the main scale. Except for 0 and 10, there can be only one vernier scale line aligned with a main scale line at any given position of the vernier slide. The number of tenths of a millimeter is the number of the line on the vernier scale which is aligned with a main scale line. Thus, in figure 3-5 the 4 line of the vernier scale is aligned with a line on the main scale. The entire reading is, therefore, 632.4 mm.

(3) From inspection of figure 3-5, it will be apparent that if the vernier slide was raised 0.1 mm, the 5-vernier scale line would coincide with the scale line it is now slightly below, and the 4-vernier scale line would be slightly above the scale line with which it now coincides. However, if the slide were raised less than 0.1 mm, neither the 4 nor the 5

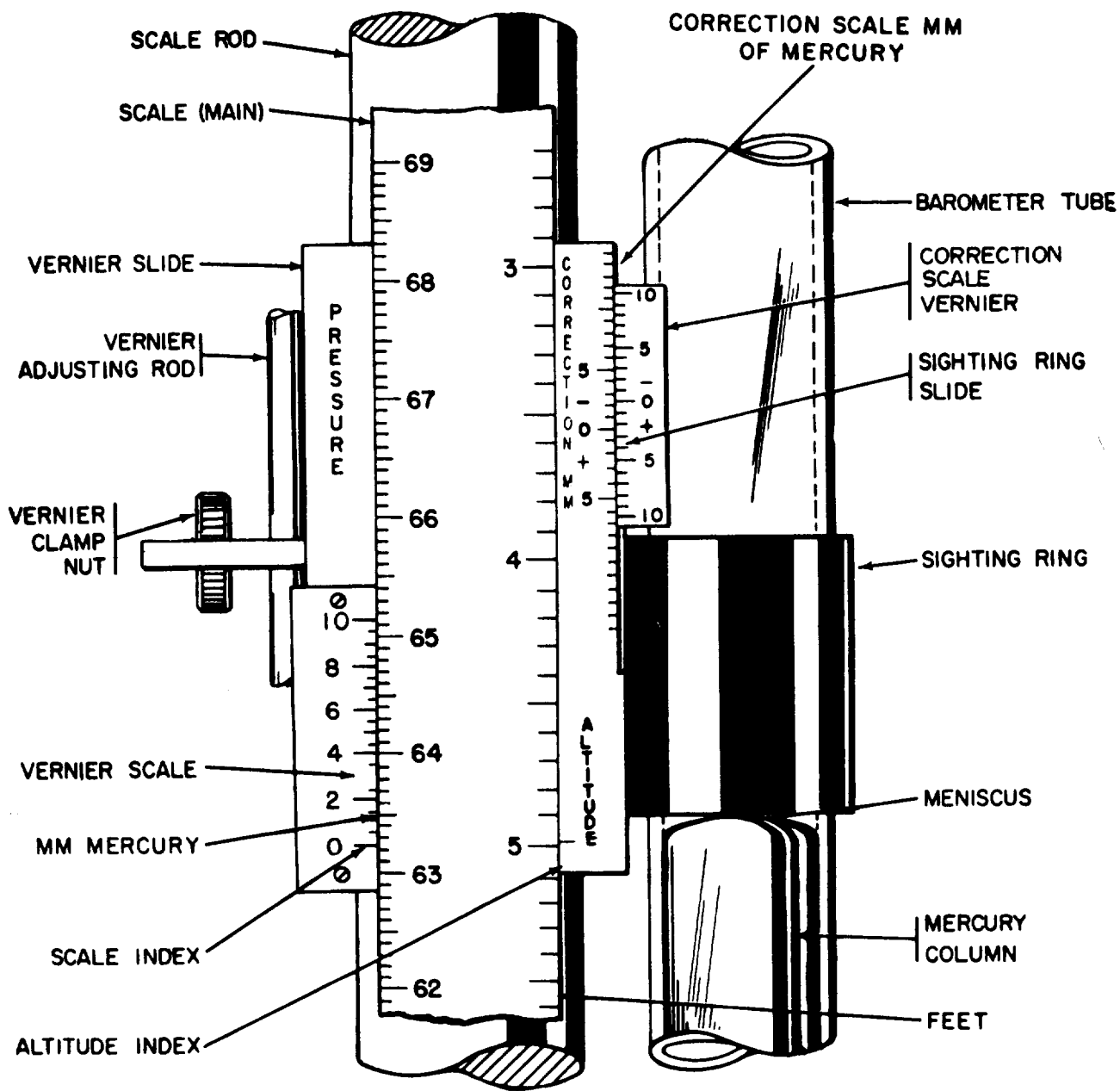

MI (C) 6685-202-14-3-5

Figure 3-5. Vernier scale and indexes-(type A-1).

would coincide. Obviously, the scale reading would be between 632.4 and 632.5. By close inspection and interpolation, the hundredths of a millimeter may be determined with fair precision. For example, if the space between the 5-vernier line and a scale line is half of that between the 4-vernier line and a scale line, it would mean the slide had been raised two-thirds of the

distance between 632.4 and 632.5, which is 632.47. The main scale vernier has an additional graduation between each 0.1 line, thus making it possible to read the vernier directly to 0.05 mm.

b. Type A-1 (Modified)

- (1) The main scale is calibrated in

millimeters from 0 to 820. On the main scale, figure 3-8, only every twentieth line is numbered. Each line between numbered lines represents 0.5 millimeter.

The vernier scale has every fifth line numbered in tenths. Each line between the numbered lines represents two hundredths of a millimeter.

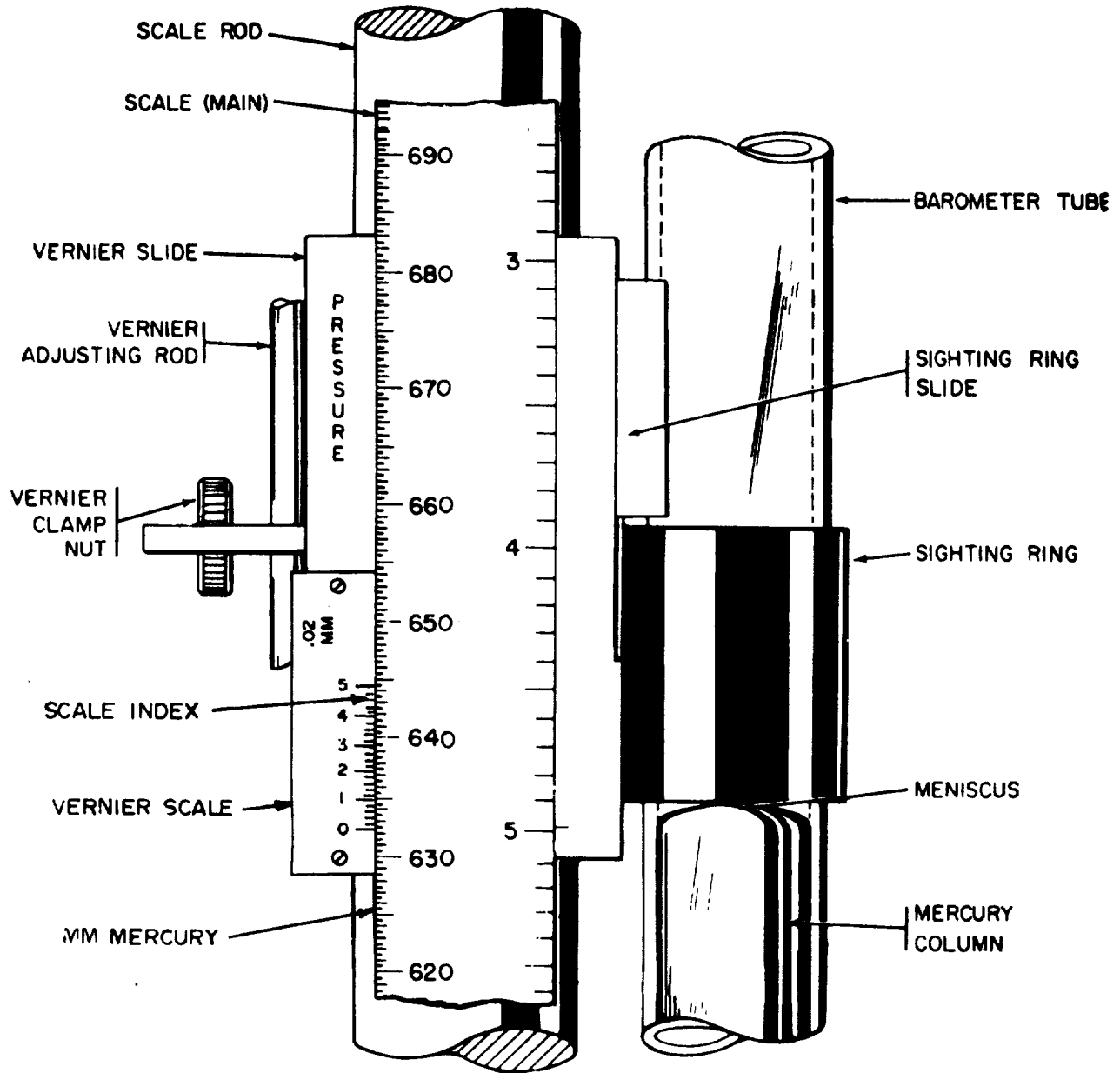

Figure 3-6. Scale and vernier-(type A-1 modified).

MI (C) 6685-202-14-3-6

(2) The number of whole millimeters and half millimeters is read at the last line on the main scale which the 0 line on the vernier scale has passed.

(3) The number of hundredths of a millimeter is found by looking along the vernier scale and noting which line of the vernier scale is aligned with any line on

the main scale. Except for 0 and .5, there can be only one vernier scale line aligned with a main-scale line at any given position of the vernier slide. Thus, in figure 3-6 the zero line on the vernier scale has passed the 632-line on the main scale and the first line past the four tenths line on the vernier scale aligns with a line on the main scale. The entire reading is, therefore, 632.42

mm. If the slide was raised 0.5 millimeters, 632.5 would be read from the main scale and .42 from the vernier scale, making the correct reading 632.92 mm.

**3-11. Reading the Micrometer (Fig. 3-7)**

- a. The point of the micrometer is adjusted toward the mercury surface until the

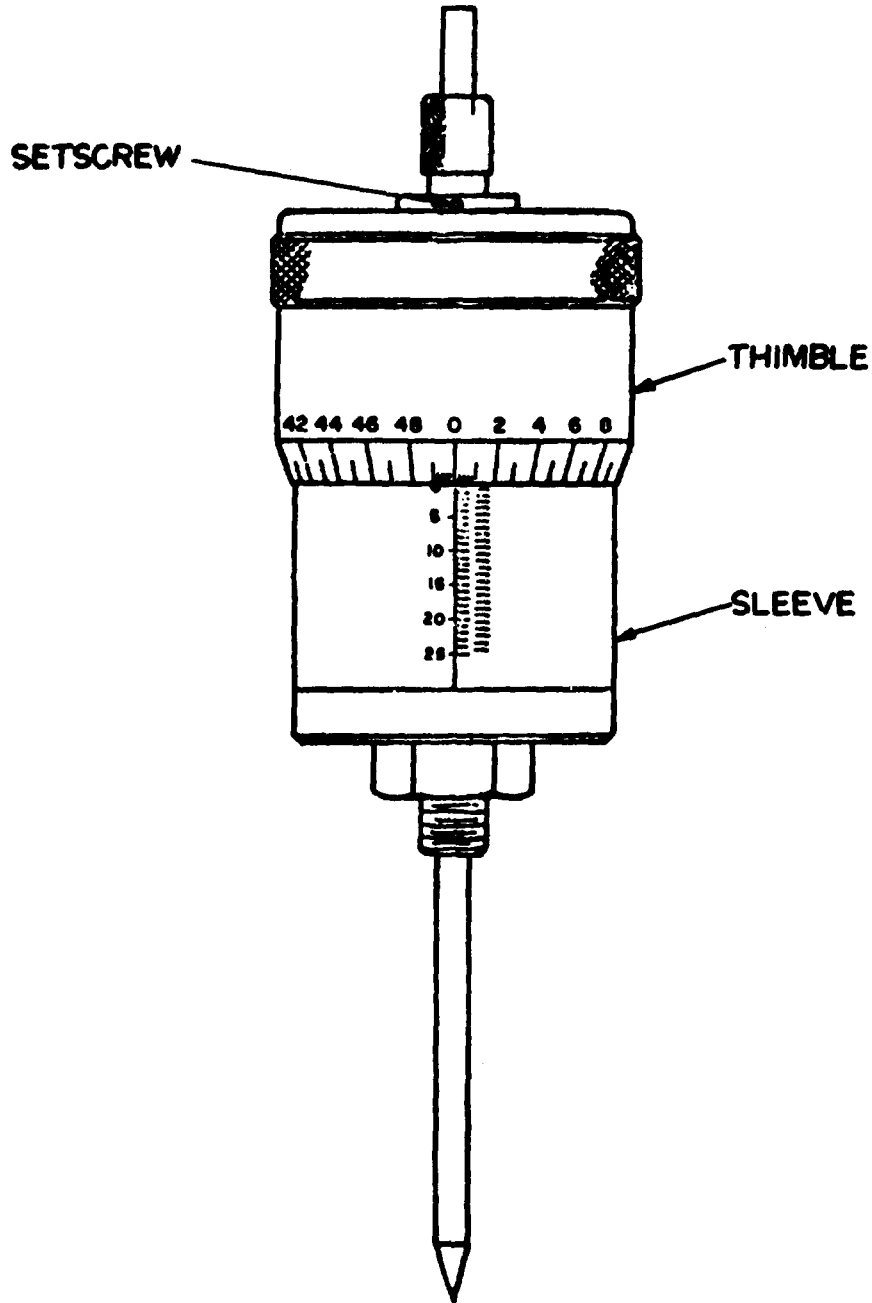

Figure 3-7. Cistern micrometer.

MI (C) 6685-202-14-3-7

point and its image reflected off the mercury surface appear to just touch by observing at a slight grazing angle.

b. The sleeve of the micrometer is calibrated in millimeters from 0 to 25 millimeters. Only every tenth line is numbered, making each line represent 0.5 millimeter. The thimble is graduated into 250 increments with only every tenth line numbered from 0 to 48 (the 50 and 0 position is the same point). One complete revolution of the thimble advances the sleeve 0.5 mm along the sleeve. Since the graduations on the thimble divide each 0.5 millimeter increment on the sleeve into 250 parts, the micrometer can be read to 0.002 mm.

**3-12. Operation as a barometer**

a. *Type A-1.* After the instrument has been prepared in accordance with paragraph 3-5 a, it is ready for use as a barometer. Precede all readings with the following checks:

- (1) Insure that the temperature adjustment agrees with the temperature indicated on the thermometer provided.
- (2) Insure that the base is level. The bubbles must be centered within one division of the leveling scales.
- (3) Rap the table to adjust the meniscus.
- (4) Read the mercury level in accordance with paragraph 3-10.

**WARNING**

**When using externally applied pressure, check that all connections are securely sealed.**

b. *Type A-1 Modified.* After the instrument has been prepared in accordance with paragraph 3-5b, it is ready for use as a barometer.

- (1) With the barometer in a level position and no pressure difference indicated on the barometer, observe the mercury height in the barometer tube and record the value as "h<sub>b</sub>." Read the scale and vernier in accordance with paragraph 3-10 b.
- (2) Measure cistern mercury height, using micrometer, in accordance with paragraph 3-11. Record micrometer indication as "h<sub>a</sub>."
- (3) Energize vacuum pump until vacuum gage indicates 20 millitorrs (microns). Maintain a vacuum on the barometer tube during measurements.
- (4) Read the main scale and vernier and record the value as "h<sub>t</sub>."

(5) Using the micrometer, measure the cistern mercury height and record the value as "h<sub>c</sub>."

(6) Substitute the values recorded in (1), (2), (4), and (5) above in the following equation and add algebraically:

$$P = C^1 [(h_t + h_c) - (h_a + h_b)]$$

(7) Solving the above equation provides the atmospheric pressure in millimeters of mercury.

**NOTE**

"C<sup>1</sup>" is a factor used to compensate for deviations from standard temperature and gravity. The value of "C<sup>1</sup>" will normally be furnished to each using activity by the calibration activity. If this value is not available, it may be determined using the equation:

$$C^1 = \frac{\rho_T \ g_L}{\rho_S \ g_S} (1 + \alpha \ \Delta t)$$

Where:  $\rho_T$  = Density of Hg at ambient temperature.

$\rho_S$  = Standard density of Hg = 13.5951 gm/cm<sup>3</sup>.

$g_L$  = Acceleration of gravity at local laboratory.

$g_S$  = Standard acceleration of gravity = 980.665 cm.sec<sup>2</sup>.

$\alpha$  = Expansion coefficient of brass.

t = Ambient temperature read from thermometer or barometer.

$\Delta t$  = Ambient temperature minus 20°C.

**NOTE**

$h_a + h_b$  is the average zero reading. A zero reading ( $h_a + h_b$ ) is taken before and after the measurements and then averaged and applied to the measurements per above equation.

**3-13. Operation as an Altimeter Calibration Instrument**

a. *Type A-1.* The barometer will measure the range of -1000 feet to +80,000 feet when utilized as an altimeter calibration instrument.

- (1) Connect the barometer into the pneumatic system (fig. 3-8).
- (2) Level the barometer and adjust the temperature index to the existing temperature. It is assumed that the gravity index was correctly positioned in preparing the barometer for use.
- (3) Adjust the vernier slide to the desired pressure-altitude by unlocking the vernier clamp nut, sliding the vernier slide to approximate setting, locking the vernier clamp nut, and making the final adjustment

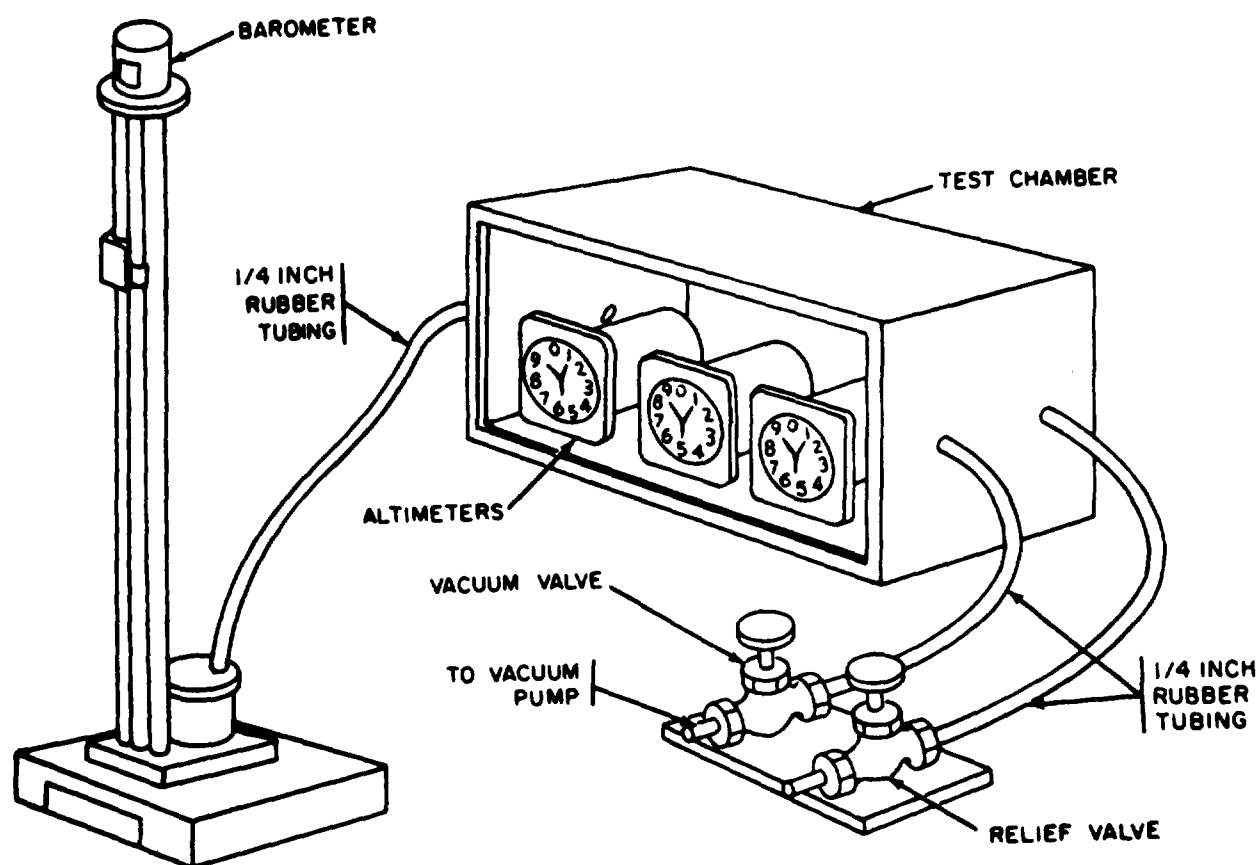

MI (C) 6685-202-14-3-8

Figure 3-8. Altimeter calibration-operating Setup.

with the vernier adjusting knob. Align the altitude index on the vernier slide with the desired altitude mark on the scale. The altitude is marked at the following intervals:

- 1,000 to 10,000 feet, marked each 100 feet,
- 10,000 to 0,000 feet, marked each 500 feet,
- 50,000 to .0,000 feet, marked each 1,000 feet.

If unmarked altitudes are desired, position the vernier slide to the pressure equivalent of the desired altitude.

(4) Open the vacuum valve slightly. The mercury will fall and the altimeters will indicate an increase in altitude. As the pressure nears the desired point, the meniscus will be inside the sighting ring but will be visible through the open side of the ring. Continue to decrease the pressure until the highest point of the meniscus appears to barely touch the lower edge of the sighting ring as in figure 3-5. If the pressure has been reduced too much as indicated by light being visible above the entire meniscus, close the vacuum

valve completely and open the relief valve slightly to allow the pressure to rise to the proper point.

**WARNING**

**The operator should not break the seal between the valve subassembly and the barometer tube while vacuum is applied.**

(5) After the pressure has been adjusted to align the mercury meniscus with the sighting ring, the pressure in the test chamber will be the same as that for the altitude which the vernier slide was set. Read and record the altimeter readings.

*b. Type A-1 Modified.* The modified barometer does not have an altitude scale for direct comparison of altimeters. However, the modified barometer can be used for



calibrating altimeters by using an altitude to pressure equivalent of any altitude from -1000 to + 80,000 feet.  
conversion table. Table 3-2 contains the pressure

**Table 3-2. Altitude to Pressure Conversion**

Altitude (feet)	Pressure		Altitude (feet)	Pressure		Altitude (feet)	Pressure	
	in. Hg	mm Hg		in. Hg	mm Hg		in. Hg	mm Hg
-1000	31.0185	787.869	3100	26.7179	678.635	7300	22.8264	579.791
-900	30.9073	785.045	3200	26.6194	676.133	7400	22.7397	577.588
-800	30.7965	782.231	3300	26.5211	673.636	7500	22.6532	575.391
-700	30.6859	779.421	3400	26.4232	671.149	7600	22.5670	573.202
-600	30.5757	776.622	3500	26.3256	668.670	7700	22.4811	571.020
-500	30.4659	773.833	3600	26.2283	666.199	7800	22.3955	568.846
-400	30.3563	771.050	3700	26.1312	663.732	7900	22.3101	566.677
-300	30.2471	768.276	3800	26.0345	661.276	8000	22.2250	564.515
-200	30.1382	765.510	3900	25.9380	658.825	8100	22.1401	562.359
-100	30.0295	762.749	4000	25.8418	656.382	8200	22.0555	560.210
0	29.9212	760.000	4100	25.7460	653.948	8300	21.9712	558.068
100	29.8132	757.258	4200	25.6504	651.520	8400	21.8871	555.932
200	29.7056	754.522	4300	25.5551	649.100	8500	21.8033	553.804
300	29.5982	751.797	4400	25.4600	646.684	8600	21.7197	551.680
400	29.4913	749.079	4500	25.3653	644.279	8700	21.6364	549.565
500	29.3846	746.369	4600	25.2709	641.881	8800	21.5534	547.456
600	29.2782	743.666	4700	25.1767	639.488	8900	21.4706	545.353
700	29.1721	740.971	4800	25.0828	637.103	9000	21.3881	543.258
800	29.0663	738.284	4900	24.9892	634.726	9100	21.3059	541.170
900	28.9608	735.604	5000	24.8959	632.356	9200	21.2238	539.085
1000	28.8557	732.935	5100	24.8029	629.994	9300	21.1421	537.009
1100	28.7508	730.270	5200	24.7101	627.637	9400	21.0606	534.939
1200	28.6462	727.616	5300	24.6177	625.290	9500	20.9794	532.877
1300	28.5421	724.969	5400	24.5255	622.948	9600	20.8984	530.819
1400	28.4382	722.330	5500	24.4336	620.613	9700	20.8177	528.770
1500	28.3345	719.696	5600	24.3420	618.287	9800	20.7372	526.725
1600	28.2312	717.072	5700	24.2506	615.965	9900	20.6569	524.685
1700	28.1282	714.456	5800	24.1595	613.651	10000	20.5770	522.656
1800	28.0255	711.848	5900	24.0687	611.345	10100	20.4972	520.629
1900	27.9231	709.247	6000	23.9782	609.046	10200	20.4178	518.612
2000	27.8210	706.653	6100	23.8880	606.755	10300	20.3385	516.598
2100	27.7193	704.070	6200	23.7980	604.469	10400	20.2596	514.594
2200	27.6178	701.492	6300	23.7083	602.191	10500	20.1808	512.592
2300	27.5166	698.922	6400	23.6189	599.920	10600	20.1024	510.601
2400	27.4157	696.359	6500	23.5298	597.657	10700	20.0241	508.612
2500	27.3151	693.804	6600	23.4405	595.399	10800	19.9461	506.631
2600	27.2148	691.256	6700	23.3521	593.148	10900	19.8684	504.657
2700	27.1148	688.716	6800	23.2640	590.906	11000	19.7909	502.689
2800	27.0152	686.186	6900	23.1755	588.668	11100	19.7137	500.728
2900	26.9158	683.661	7000	23.0881	586.438	11200	19.6367	498.772
3000	26.8167	681.144	7100	23.0006	584.215	11300	19.5599	496.821
			7200	22.9132	581.998			

Table 3-2. Altitude to Pressure Conversion-Continued

Altitude (feet)	Pressure		Altitude (feet)	Pressure		Altitude (feet)	Pressure	
	in. Hg	mm Hg		in. Hg	mm Hg		in. Hg	mm Hg
11400	19.4834	494.878	16000	16.2164	411.897	20600	13.4079	340.561
11500	19.4071	492.940	16100	16.1507	410.228	20700	13.3516	339.131
11600	19.3311	491.010	16200	16.0852	408.564	20800	13.2954	337.703
11700	19.2553	489.085	16300	16.0199	406.905	20900	13.2395	336.283
11800	19.1797	487.164	16400	15.9548	405.252	21000	13.1837	334.866
11900	19.1044	495.252	16500	15.8899	403.603	21100	13.1281	333.454
12000	19.0294	483.347	16600	15.8252	401.960	21200	13.0727	332.047
12100	18.9545	481.444	16700	15.7608	400.324	21300	13.0175	330.645
12200	18.8799	479.549	16800	15.6966	398.694	21400	12.9625	329.248
12300	18.8056	477.662	16900	15.6325	397.066	21500	12.9076	327.853
12400	18.7315	475.780	17000	15.5687	395.445	21600	12.8530	326.466
12500	18.6576	473.903	17100	15.5051	393.830	21700	12.7985	325.082
12600	18.5839	472.031	17200	15.4417	392.219	21800	12.7443	323.705
12700	18.5105	470.167	17300	15.3785	390.614	21900	12.6902	322.331
12800	18.4374	468.310	17400	15.3156	389.016	22000	12.6363	320.962
12900	18.3644	466.456	17500	15.2528	387.421	22100	12.5826	319.598
13000	18.2917	464.609	17600	15.1903	385.834	22200	12.5291	318.239
13100	18.2192	462.768	17700	15.1279	384.249	22300	12.4757	316.883
13200	18.1470	460.934	17800	15.0658	382.671	22400	12.4226	315.534
13300	18.0750	459.105	17900	15.0038	381.097	22500	12.3696	314.188
13400	18.0032	457.281				22600	12.3168	312.847
13500	17.9317	455.465	18000	14.9421	379.529	22700	12.2642	411.511
13600	17.8603	453.652	18100	14.8806	377.967	22800	12.2118	310.180
13700	17.7893	451.848	18200	14.8193	376.410	22900	12.1595	308.851
13800	17.7184	450.047	18300	14.7582	374.858	23000	12.1075	307.531
13900	17.6478	448.254	18400	14.6973	373.311	23100	12.0556	306.212
14000	17.5774	446.466	18500	14.6366	371.770	23200	12.0039	304.899
14100	17.5072	444.683	18600	14.5761	370.233	23300	11.9524	303.591
14200	17.4373	442.907	18700	14.5158	368.701	23400	11.9010	302.285
14300	17.3675	441.135	18800	14.4557	367.175	23500	11.8499	300.987
14400	17.2981	439.372	18900	14.3958	365.653	23600	11.7989	299.692
14500	17.2288	437.612	19000	14.3361	364.137	23700	11.7481	298.402
14600	17.1597	435.856	19100	14.2766	362.626	23800	11.6974	297.114
14700	17.0909	434.109	19200	14.2173	361.119	23900	11.6470	295.834
14800	17.0223	432.366	19300	14.1582	359.618	24000	11.5967	294.556
14900	16.9540	430.632	19400	14.0993	358.122	24100	11.5466	293.284
15000	16.8858	428.899	19500	14.0406	356.631	24200	11.4967	292.016
15100	16.8179	427.175	19600	13.9821	355.145	24300	11.4469	290.751
15200	16.7502	425.455	19700	13.9238	353.665	24400	11.3974	289.494
15300	16.6827	423.741	19800	13.8657	352.189	24500	11.3480	288.239
15400	16.6154	422.031	19900	13.8078	350.718	24600	11.2987	286.987
15500	16.5484	420.329				24700	11.2497	285.742
15600	16.4816	418.633	20000	13.7501	349.253	24800	11.2008	284.500
15700	16.4150	416.941	20100	13.6926	347.792	24900	11.1521	283.263
15800	16.3486	415.254	20200	13.6353	346.337	25000	11.1035	282.029
15900	16.2824	413.573	20300	13.5782	344.886	25100	11.0552	280.802
			20400	13.5212	343.438			
			20500	13.4645	341.998			

Table 3-2. Altitude to Pressure Conversion-Continued

Altitude (feet)	Pressure		Altitude (feet)	Pressure		Altitude (feet)	Pressure	
	in. Hg	mm Hg		in. Hg	mm Hg		in. Hg	mm Hg
25200	11.0070	279.578	29800	8.96665	227.753	34300	7.27834	184.870
25300	10.9589	278.356	29900	8.92597	226.720	34400	7.24399	183.997
25400	10.9111	277.142	30000	8.88544	225.690	34500	7.20977	183.128
25500	10.8634	275.930	30100	8.84506	224.665	34600	7.17568	182.262
25600	10.8159	274.724	30200	8.80483	223.643	34700	7.14172	181.400
25700	10.7685	273.520	30300	8.76475	222.625	34800	7.10789	180.540
25800	10.7213	272.321	30400	8.72481	221.610	34900	7.07419	179.684
25900	10.6743	271.127	30500	8.6850Z	220.600	35000	7.04062	178.832
26000	10.6275	269.939	30600	8.64539	219.593	35200	6.97386	177.136
26100	10.5808	268.752	30700	8.60589	218.590	35400	6.90762	175.454
26200	10.5343	267.571	30800	8.56654	217.590	35600	6.84189	173.784
26300	10.4879	266.393	30900	8.52734	216.594	35800	6.77667	172.127
26400	10.4417	265.219		8.52734	216.594	36000	6.71195	170.484
26500	10.3957	264.051	31000	8.48829	215.603	36200	6.64775	168.853
26600	10.3499	262.887	31100	8.44938	214.614	36400	6.58415	167.237
26700	10.3042	261.727	31200	8.41061	213.629	36600	6.52116	165.637
26800	10.2587	260.571	31300	8.37199	212.649	36800	6.45878	164.053
26900	10.2133	259.418	31400	8.33351	211.671	37000	6.39699	162.484
27000	10.1681	258.270	31500	8.29517	210.697	37200	6.33579	160.929
27100	10.1230	257.124	31600	8.25698	209.727	37400	6.27518	159.390
27200	10.0782	255.986	31700	8.21893	208.761	37600	6.21515	157.865
27300	10.0335	254.851	31800	8.18102	207.798	37800	6.15569	156.355
27400	9.98889	253.718	31900	8.14326	206.839	38000	6.09680	154.859
27500	9.94450	252.590		8		38200	6.03847	153.377
27600	9.90026	251.467	32000	8.10563	205.883	38400	5.98071	151.910
27700	9.85619	250.347	32100	8.06815	204.931	38600	5.92349	150.457
27800	9.81227	249.232	32200	8.03081	203.983	38800	5.86682	149.017
27900	9.76851	248.120	32300	7.99360	203.037	39000	5.81070	147.592
			32400	7.95654	202.096	39200	5.75511	146.180
28000	9.72491	247.013	32500	7.91961	201.158	39400	5.70005	144.781
28100	9.68147	245.909	32600	7.88283	200.224	39600	5.64552	143.396
28200	9.63818	244.810]	32700	7.84618	199.293	39800	5.59151	142.024
28300	9.59505	243.714	32800	7.80967	198.366	40000	5.53802	140.666
28400	9.55208	242.623	32900	7.77330	197.442	40200	5.48504	139.320
28500	9.50926	241.535	33000	7.73707	196.522	40400	5.43257	137.987
28600	9.46660	240.452	33100	7.70097	195.605	40600	5.38060	136.667
28700	9.42410	239.372	33200	7.66501	194.691	40800	5.32912	135.360
28800	9.38174	238.296	33300	7.62919	193.781	41000	5.27814	134.065
28900	9.33955	237.225	33400	7.59350	192.875	41200	5.22765	132.782
			33500	7.55794	191.972	41400	5.17763	131.512
29000	9.29750	236.157	33600	7.52253	191.072	41600	5.12810	130.254
29100	9.25561	235.092	33700	7.48724	190.176	41800	5.07904	129.008
29200	9.21388	234.020	33800	7.45209	189.283	42000	5.03045	127.773
29300	9.17229	232.976	33900	7.41708	188.394	42200	4.98233	126.551
29400	9.13086	231.924				42400	4.93466	125.340
29500	9.08958	230.875	34000	7.38219	187.508	42600	4.88746	124.141
29600	9.04845	229.831	34100	7.34744	186.625			
29700	9.00747	228.790	34200	2.31283	185.746			

Altitude (feet)	Pressure		Altitude (feet)	Pressure		Altitude (feet)	Pressure	
	in. Hg	mm Hg		in. Hg	mm Hg		in. Hg	mm Hg
42800	4.84070	122.954	51800	3.14083	79.777	61000	2.01840	51.267
43000	4.79439	121.778	52000	3.11079	79.014	61200	1.99909	50.777
43200	4.74852	120.612	52200	3.08103	78.258	61400	1.97996	50.291
43400	4.70310	119.459	52400	3.05155	77.509	61600	1.96102	49.810
43600	4.65810	118.316	52600	3.02236	76.768	61800	1.94226	49.333
43800	4.61354	117.184	52800	2.99344	76.033	62000	1.92368	48.861
44000	4.56941	116.063	53000	2.96481	75.306	62200	1.90528	48.394
44200	4.52569	114.953	53200	2.93644	74.586	62400	1.88705	47.931
44400	4.48240	113.853	53400	2.90835	73.872	62600	1.86900	47.473
44600	4.43951	112.764	53600	2.88053	73.165	62800	1.85112	47.018
44800	4.39704	111.685	53800	2.85297	72.465	63000	1.83341	46.569
45000	4.35498	110.616	54000	2.82568	71.772	63200	1.81587	46.123
45200	4.31332	109.558	54200	2.79865	71.086	63400	1.79850	45.682
45400	4.27205	108.510	54400	2.77187	70.405	63600	1.78129	45.245
45600	4.23118	107.472	54600	2.74535	69.732	63800	1.76425	44.812
45800	4.19070	106.444	54800	2.71909	69.065	64000	1.74737	44.383
46000	4.15061	105.423	55000	2.69308	68.404	64200	1.73066	43.959
46200	4.11091	104.417	55200	2.66731	67.750	64400	1.71410	43.538
46400	4.07158	103.418	55400	2.64180	67.102	64600	1.69770	43.122
46600	4.03263	102.429	55600	2.61652	66.460	64800	1.68146	42.709
46800	3.99405	101.449	55800	2.59149	65.824	65000	1.66537	42.300
47000	3.95584	100.478	56000	2.56670	65.194	65200	1.64944	41.896
47200	3.91800	99.517	56200	2.54215	64.571	65400	1.63366	41.495
47400	3.88051	98.565	56400	2.51783	63.953	65600	1.61803	41.098
47600	3.84339	97.622	56600	2.49374	63.341	65800	1.60256	40.705
47800	3.80662	96.688	56800	2.46988	62.735	66000	1.58723	40.316
48000	3.77020	95.763	57000	2.44625	62.135	66200	1.57206	39.930
48200	3.73414	94.847	57200	2.42285	61.540	66400	1.55703	39.549
48400	3.69841	93.940	57400	2.39967	60.952	66600	1.54216	39.171
48600	3.66303	93.041	57600	2.37672	60.369	66800	1.52742	38.796
48800	3.62799	92.151	57800	2.35398	59.791	67000	1.51284	38.426
49000	3.59328	91.269	58000	2.33146	59.219	67200	1.49840	38.059
49200	3.55891	90.396	58200	2.30916	58.653	67400	1.48410	37.696
49400	3.52486	89.531	58400	2.28706	58.091	67600	1.46994	37.336
49600	3.49114	88.675	58600	2.26519	57.536	67800	1.45591	36.980
49800	3.45774	87.827	58800	2.24351	56.985	68000	1.44203	36.628
50000	3.42466	86.986	59000	2.22205	56.440	68200	1.42828	36.278
50200	3.39190	86.151	59200	2.20079	55.900	68400	1.41467	35.933
50400	3.35945	85.330	59400	2.17974	55.365	68600	1.40119	35.590
50600	3.32731	84.514	59600	2.15889	54.836	68800	1.38784	35.251
50800	3.29548	83.705	59800	2.13823	54.311	69000	1.37463	34.916
51000	3.26395	82.904	60000	2.11778	53.792	69200	1.36154	34.583
51200	3.23273	82.111	60200	2.09752	53.277	69400	1.34858	34.254
51400	3.20180	81.326	60400	2.07745	52.767	69600	1.33575	33.928
51600	3.17117	80.548	60600	2.05758	52.263	69800	1.32304	33.605
			60800	2.03789	51.762	70000	1.31046	33.286
						70200	1.29800	32.969

Altitude (feet)	Pressure		Altitude (feet)	Pressure		Altitude (feet)	Pressure	
	in. Hg	mm Hg		in. Hg	mm Hg		in. Hg	mm Hg
70400	1.28567	32.656	73800	1.09345	27.774	77000	0.939529	23.864
70600	1.27345	32.346	74000	1.08311	27.511	77200	0.930682	23.639
70800	1.26135	32.038	74200	1.07287	27.251	77400	0.921922	23.417
71000	1.24938	31.734	74400	1.06273	26.993	77600	0.913248	23.196
71200	1.23751	31.433	74600	1.05269	26.738	77800	0.904656	22.978
71400	1.22577	31.135	74800	1.04274	26.486	78000	0.896148	22.762
71600	1.21414	30.839	75000	1.03290	26.236	78200	0.887722	22.548
71800	1.20262	30.547	75200	1.02314	25.988	78400	0.879377	22.336
72000	1.19122	30.257	75400	1.01349	25.743	78600	0.871114	22.126
72200	1.17992	29.970	75600	1.00392	25.500	78800	0.862931	21.918
72400	1.16874	29.686	75800	0.994453	25.259	79000	0.854826	21.713
72600	1.15767	29.405	76000	0.985074	25.021	79200	0.846799	21.509
72800	1.14670	29.126	76200	0.975787	24.785	79400	0.838851	21.307
73000	1.13584	28.850	76400	0.966589	24.551	79600	0.830979	21.107
73200	1.12509	28.577	76600	0.957481	24.320	79800	0.823183	20.909
73400	1.11444	28.307	76800	0.948461	24.091	80000	0.815462	20.713
73600	1.10389	28.039						

(1) Prepare the modified barometer in accordance with paragraph 3-5 b.

(2) Connect the barometer into the pneumatic system (fig. 3-8).

(3) Energize the vacuum pump and evacuate the barometer tube to 20 millitorrs (microns).

(4) Open the vacuum valve (fig. 3-8) slightly. Operate the vacuum valve and relief valve (fig. 3-8) to obtain the desired indication on the altimeter.

(5) Compute the barometer pressure indication in accordance with paragraph 3-12b and obtain the equivalent altitude from table 3-2.

**3-14. Operation as a Gage Pressure Manometer**

a. *Type A-1.* The maximum pressure which can be measured using the barometer as a gage pressure manometer is 790 mm of mercury or 15.276 psi.

(1) Open the tube seal valve at the top of barometer and leave it open.

(2) Level the instrument and adjust the temperature correction if necessary.

(3) Apply the pneumatic pressure to be measured to the cistern by means of 1/4-inch rubber tube connected to the cistern nipple (fig. 1-2).

**NOTE**

The mercury which is normally above the tube seal valve is now in the system and causes the barometer to read 0.1 mm high. Therefore, 0.1 mm should be subtracted from all readings.

(4) For extended use as a manometer, it may be desirable to remove approximately 1/2 cc of mercury from the cistern to eliminate the correction noted above. Follow the procedure described in paragraph 4-5a, adjusting the mercury level so that the barometer reads zero.

b. *Type A-1 Modified.* The maximum absolute pressure which can be measured using the modified barometer is 790 mm of mercury or 15.277 psi. Gage pressures up to 15 psi can also be measured.

(1) Prepare the modified barometer in accordance with paragraph 3-5b.

(2) Open the tube evacuation line and valve to vent the tube to atmosphere.

(3) Apply the pneumatic pressure to be measured to the cistern nipple (fig. 3-8).

(4) Compute the pressure indication in accordance with paragraph 3-12b.

**3-15. Operation as a Differential Pressure Manometer**

a. *Type A-1*

(1) Open the tube seal valve and leave it open.

(2) Level the instrument and adjust the temperature correction, if necessary.

(3) Connect the low pressure side of the system to be measured to the tube-evacuation nipple (fig. 1-2).

(4) Connect the high pressure side of the system to be measured to the cistern nipple.

(5) Open appropriate valves to apply pressures.

(6) Subtract 0.1 mm from the reading to compensate for the additional mercury as noted in paragraph 3-14.

*b. Type A-1 Modified.* Differential pressures between 0 and 790 millimeters of mercury (approximately 15 psi) can be measured with the modified barometer.

(1) Prepare the modified barometer in accordance with paragraph 3-5*b*.

(2) Connect the low pressure side of the system to be measured to the barometer tube evacuation connection.

(3) Connect high pressure side of the system to be measured to the cistern nipple.

(4) Open the appropriate valves to apply pressures.

(5) Compute the differential pressure indication in accordance with paragraph 3-12*b*.

**3-16. Operation as a Vacuum Manometer**

*a. Type A-1*

(1) Open the tube seal valve, and leave it open.

(2) Level the barometer and adjust the temperature correction if necessary.

(3) Connect the vacuum source to be measured to the tube evacuation nipple (fig. 1-2).

(4) Subtract 0.1 mm from the reading to compensate for the additional mercury as noted in paragraph 3-14.

*b. Type A-1 Modified*

(1) Prepare the modified barometer in accordance with paragraph 3-5*b*.

(2) Connect the vacuum source to be measured to the barometer tube evacuation connection.

(3) Compute the vacuum indication in accordance with paragraph 3-12 *b*.

**3-17. Operation as an Absolute Pressure Manometer**

*a. Type A-1.* Using the instrument as an absolute pressure manometer is identical to using it as a barometer, except that the pressure to be measured rather than atmospheric pressure is applied to the cistern. Refer to paragraph 3-12*a* for operation as a barometer.

*b. Type A-1 Modified.* Using the instrument as an absolute pressure manometer is identical to using it as a barometer, except that the pressure to be measured rather than atmospheric pressure is applied to the cistern. Refer to paragraph 3-12*b* for operation as a barometer.

## CHAPTER 4 MAINTENANCE INSTRUCTIONS

---

### Section I. PARTS, SPECIAL TOOLS, AND EQUIPMENT FOR OPERATORS

#### 4-1. Parts and Tools

a. Tools, equipment, and spare parts issued to using personnel for operating and maintaining the material should not be used for purposes other than prescribed and, when not in use, should be properly stored in the containers provided for them. No special tools are required to support the barometer.

b. Spare parts are supplied to using personnel for the replacement of those parts most likely to become unserviceable, if such operations are within the scope of their maintenance functions. Spare parts, tools, and

equipment supplied for the barometer and auxiliary equipment are listed in appendix C, which is the authority for requisitioning replacements in accordance with TM 9-4931-700-34P-1.

#### 4-2. Test Equipment

There is no test equipment required to support the barometer. The test equipment required to calibrate the barometer will be available in the laboratory which is responsible for the support of the barometer (refer to TB 750-25).

### Section II. PREVENTIVE MAINTENANCE SERVICES

#### 4-3. General

a. *Preventive Maintenance.* This is the systematic care, inspection, and servicing of equipment to maintain it in serviceable condition, prevent breakdowns, and assure maximum operational readiness. The operator's role in the performance of preventive maintenance service is to:

(1) Perform the daily service required each day the equipment is operated.

(2) Assist the maintenance mechanics in the performance of any other scheduled periodic services specified by pertinent technical manuals.

(3) Assist the maintenance mechanics in the lubrication of the equipment in accordance with the pertinent lubrication order.

b. *Responsibility.* Operators are personally responsible for assigned equipment. Unit and organization commanders are required to insure that equipment issued or assigned to their command is properly maintained in a serviceable condition, and that it is properly cared for and used.

c. *General Procedures for All Services and Inspections.* The following general procedures apply to

operator preventive maintenance services and all inspections and are just as important as the specific procedures:

(1) Inspections to see if items are in good condition, correctly assembled or stowed, not excessively worn, not leaking, and adequately lubricated apply to most items in the preventive-maintenance and inspection procedures. Any or all of these checks that are pertinent to any item (including supporting, attaching, or connecting members) will be performed automatically, as general procedures, in addition to any specific procedures given.

(a) Inspection for "good condition" is usually an external visual inspection to determine whether the unit is damaged beyond safe or serviceable limits. Good condition is explained further as meaning: not bent or twisted, not chafed or burred, not broken or cracked, not bared or frayed, not dented or collapsed, not torn or cut, not deteriorated.

(b) Inspection of a unit to see that it is "correctly assembled" or stowed is usually a visual inspection to see if the unit

is in its normal position in the equipment and if all its parts are present and in their correct relative position.

(c) By "excessively worn" is meant worn beyond serviceable limits or to a point likely to result in failure if the unit is not replaced before the next scheduled inspection. Excessive wear of mating parts of linkage connection is usually evidenced by too much play (lash or lost motion). It includes illegibility as applied to markings, data and caution plates, and printed matter.

(d) such expressions as "adjust if necessary" or "replace if necessary" are not used in the

specific procedures. *It is understood that whenever inspection reveals the need of adjustment, repairs or replacement, the necessary action will be taken.*

(2) Special cleaning instructions required for specific mechanisms or parts are contained in paragraph 4-13.

#### **4-4. Preventive Maintenance Checks and Services**

Table 4-1 gives the specific procedures to be performed on the barometer by the operator for each daily or periodic service.



**Table 4-1. Preventive-Maintenance Checks and Service**

INTERVAL AND SEQUENCE NUMBER			ITEM TO BE INSPECTED	PROCEDURES	PARAGRAPH REFERENCES.
BEFORE OPERATION	DURING OPERATION	AFTER OPERATION			
1			Mounting platform.	Daily Service Check that barometer is level within one division on leveling scales, if not, adjust leveling screws.	3-5
2			Lamp and batteries	Check that lamp operates. If not, replace if defective, or check and replace batteries.	4-5f and g
3			Cistern and barometer tube.	Check visually for contamination introduced by auxiliary equipment. Refer instrument to maintenance for replacement of contaminated mercury.	4-5b
				Weekly Service	
1			Barometer tube	Perform referenced paragraph to assure that no air bubble is present above the mercury level.	4-5d
2			Rods, scale, and cam bar type A-1.	Wipe scale rod, thermometer rod, cam, bar, and scale with a few drops of instrument oil.	4-13
1			Computing-correcting mechanism and applied correction scale (type A-1).	Every 6 Months Applied correction agrees with computed value within 0.10 mm.  If error is constant, adjust vernier strip. If error is larger than 0.10 mm and variable, refer instrument to depot for recalibration.	4-5c

**Table 4-1. Preventive-Maintenance Checks and Services-Continued**

INTERVAL AND SEQUENCE NUMBER			ITEM TO BE INSPECTED	PROCEDURES	PARAGRAPH REFERENCES.
BEFORE OPERATION	DURING OPERATION	AFTER OPERATION			
1			Mercury level in barometer.	Check mercury level	4-5a 3-5
2			Moisture in baro- meter tube.	Perform referenced procedure if moisture has collected in baro- meter tube or cistern has been left open to atmosphere.	
1			Adjusting rod (and cam positioning assembly (type A-1).	Annually Lubricate annually or when adjust- ments become difficult to perform.	4-13

#### 4-5. Detailed Procedures

a. **Checking the Level of Mercury.** As long as the barometer is operating properly and the accuracy is within limits specified in table 1-1, the mercury level need not be checked. When there is reason to suspect that mercury has been added or removed from the barometer, the amount of mercury should be checked. It should read 0.1 mm. If it does not, add or remove mercury as specified in paragraph 4-5b. Prior to checking the amount of mercury, the barometer must be completely prepared for use as specified in paragraph 3-5.

b. *Adding or Removing Mercury.*

#### WARNING

**Mercury vapors are dangerous. Mercury must be handled with care in a well-ventilated room. Wash hands before handling food or cigarettes. Do not touch the mercury as oil from the skin will contaminate it.**

(1) *Type A-1*

(a) Prepare the barometer for use as specified in paragraph 3-5.

(b) Open cistern and barometer tube to atmospheric pressure and leave valves open.

(c) Remove the cistern nipple.

(d) Fill barometer with triple-distilled mercury until barometer indicates 0.1 mm. On the type A-1 barometer, the temperature and gravity indexes must be set for the existing conditions.

#### NOTE

**It is usually better practice to overfill the barometer slightly, then skim off the excess to adjust to zero.**

(e) Use filtering flask MS-306066-3, rubber stopper ZZ-S-751, pipet 7913319, and tygon tubing connected to the vacuum pump as shown in figure 4-1 to remove excess mercury from the cistern.

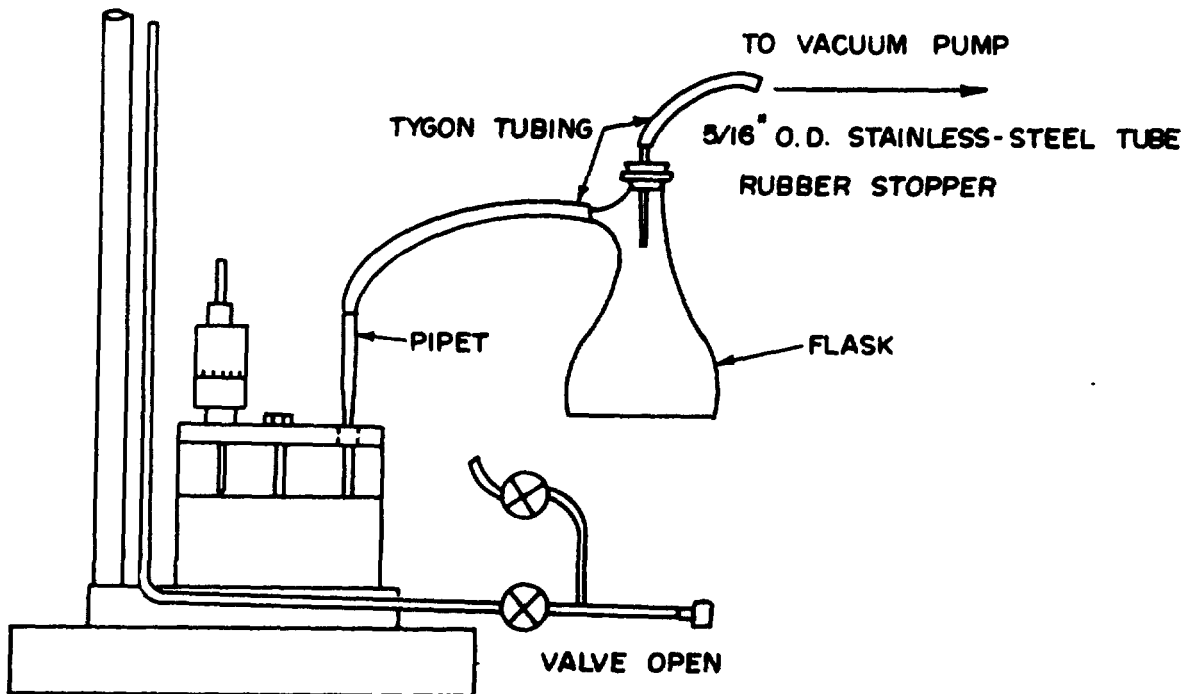

MI (C) 6685-202-14-4-1

Figure 4-1. Removal of mercury.

**NOTE**

Keep pipet tip slightly above mercury surface when removing mercury. This will help skim off impurities that may have accumulated during the filling operation. Always remove pipet completely from cistern when checking scale zero since the vacuum source will cause a slight pressure differential between the cistern and barometer tube.

(f) Reinstall the cistern nipple and tighten it securely.

(2) *Type A-1 Modified*

(a) Prepare the barometer for use as specified in paragraph 3-5.

(b) Pour approximately 6-1/2 pounds of triple-distilled mercury into a clean filtering flask MS-306066-3.

(c) Remove the cistern nipple, install antisplash tube 7913094 into bottom of cistern nipple, and reinstall the nipple in the cistern.

(d) Connect the barometer, filtering flask, and glass trap to the vacuum pump as shown in figure 4-2.

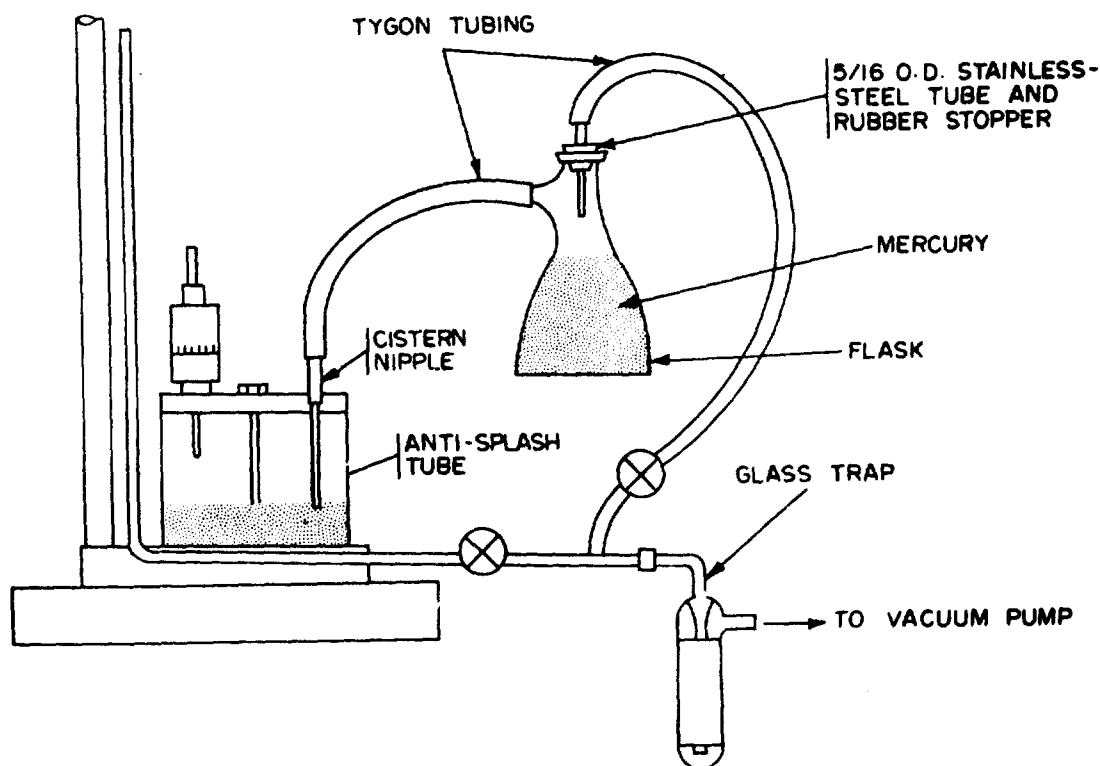

MI (C) 6685-202-14-4-2

**Figure 4-2. Installation of mercury-(type A-1 modified).**

(e) Operate the vacuum pump until 50 microns is indicated on the vacuum gage with both valves open.

(f) When this pressure is reached, tilt the filtering flask over slowly to let the mercury run down the side of the tube. Add mercury to bring the level up to zero on the main scale.

(g) Deenergize the vacuum and slowly raise the pressure to ambient on the cistern and barometer tube.

(h) Remove antisplash tube and

reinstall cistern nipple securely.

(i) Excess mercury can be removed from cistern in accordance with paragraph 4-5 b (1) (e) above.

c. *Checking the Computing-Correcting Mechanism (Type A-1 only).* The computing-correcting mechanism should be checked when the barometer is originally set up, thereafter every 6 months, or any time the barometer has been subject to damage. Fastened to the sighting ring slide is a vernier strip which, with the applied correction

scale on the vernier slide, indicates the direction and magnitude of the correction being applied. The applied correction indicated is the combined total of the gravity and temperature correction. This correction can be checked against predetermined values as follows:

- (1) Adjust the gravity index to standard gravity (980.665), using the two screws holding the temperature-gravity scale, figure 1-3.
- (2) Set the temperature index to 10° C.
- (3) Position the vernier slide assembly at each of the settings given in table 4-2 and note the correction indicated at each setting.
- (4) Repeat (3) above for temperature settings given in table 4-2.
- (5) Compare the values of the indicated applied correction with the computed values given in

table 4-2. The applied correction in each case should agree with the computed values within 0.10 mm of mercury.

d. *Removing an Air Bubble from the Tube (Type A-1 only).* After a period of time, an air bubble will accumulate above the mercury in the tube. The bubbles can be forced out through the valve subassembly in the top of the tube by the application of an external pump pressure. During the first several weeks of operation, this air bubble should be removed at the beginning of each day the barometer is in use. Later, once a week will be sufficient. Since the bubble removal procedure is simple and requires little time, its use at more frequent intervals than that specified above, is desirable. When removing an air bubble use the following procedure:

**Table 4-2. Applied Correction Vernier Readings (mm)**

MODEL 10-00-00-F					
SCALE READING MM.	TEMPERATURE SETTING (GRAVITY MUST BE SET AT 980.665).				
	10° C	20° C	25° C	30° C	40° C
770	+1.95	+.65	00	-.65	-1.95
670	+1.71	+.57	00	-.57	-1.71
570	+1.46	+.49	00	-.49	-1.46
470	+1.22	+.41	00	-.41	-1.22
370	+.98	+.33	00	-.33	-.98
270	+.73	+.24	00	-.24	-.73
170	+.49	+.16	00	-.16	-.49
70	+.24	+.08	00	-.08	-.24
0	+.07	+.02	00	-.02	-.07

(1) Connect the vacuum pump to the tube evacuation nipple.

(2) After the pump has run for approximately 1 minute, apply enough pressure to the cistern by means of the hand blower (furnished in the barometer drawer) to force the mercury up to the top of the tube. As the mercury nears the top, if there is air in the tube, it will be seen escaping through the mercury above the sealing ball. It is not necessary to open the tube seal valve. Considerable pressure may be applied to the cistern without forcing additional mercury past the valve,

thereby making it unnecessary to readjust the amount of mercury above the valve. However, if additional mercury is forced up, readjust the mercury to the orange calibration line in accordance with paragraph 3-5 (2).

**CAUTION**

**When removing air bubble, extreme caution should be exercised to avoid forcing mercury into the vacuum system.**

- (3) Release the cistern pressure.
- (4) Remove the vacuum pump.

*e. Removing Moisture from the Barometer Tube.* If the procedures of paragraph 3-5 are followed closely, it is improbable that there will be any moisture in the tube. However, it is possible for moisture to collect in the cistern due to condensation if the cistern is left open to atmospheric pressure. Under certain circumstances some of this moisture may be transferred to the tube by the mercury. Moisture in the tube will form water vapor above the mercury which will depress the column in the same manner as an air bubble. However, it cannot be removed in the same manner as an air bubble because as pressure is applied to force the vapor past the tube seal valve it will merely condense and revaporize as the pressure is released. In removing moisture, follow the same general procedure as in preparing the barometer for use after shipment or storage. Refer to paragraph 3-5.

*f. Replacing the Light Bulb.* Unscrew the light bulb from its bracket. Replace with GE Type 323, 3 volts, 0.19 amperes, instrument light bulb, Federal stock number 6240-155-7864.

*g. Replacing the Batteries.* The batteries can be replaced, using the method described in paragraph 3-4. Batteries should be replaced at regular intervals before they can become overaged and swell in the tube. They should be removed if the instrument is not to be used for a considerable period.

**4-6. Operator's Maintenance of Vacuum Pump 3410-203-3057 or 4931-929-8403**

*a. General.* Operator maintenance of the vacuum pump is confined to visual inspection and changing of the oil used in the pump.

*b. Maintaining Oil Level.* Maintain the oil level in the pump as follows:

(1) Fill pump with Cenco No. 93050 vacuum pump lubricating oil, Federal stock number 9150-273-8663, to sight level line as indicated in window on one side of pump. On the 4310-203-3057 vacuum pump remove the top cover for filling. The 4931-929-8403 is filled by pouring oil through the exhaust port.

(2) Frequency of oil change depends on service or use of pump. In a vaporless and dustless system, change oil only once every 6 months.

(3) When oil has been contaminated, drain from the pump. Flush pump with oil (Cenco No. 93050, or equal) and refill with vacuum pump lubricating oil, Cenco No. 93050, Federal stock number 9150-273-8663.

(4) Most of the oil can be drained through the drain cock. To completely remove all oil, remove cover, invert pump, and turn shaft through several revolutions.

**4-7. Operator Maintenance of Constant Vacuum Regulator 6685-306-5604**

Operator responsibility for the maintenance of the vacuum regulator is confined to visual inspection and operation of the regulator.

**4-8. Recording Repairs**

Repairs will be made in accordance with procedures and standards prescribed in appropriate technical manuals. The equipment record system provides for recording required repairs accomplished on specific items of equipment. This will include, but is not limited to, adjusting, cleaning, and replacement. Deficiencies discovered before, during, and after operation that cannot be corrected by the operator will be reported on DA Form 2404. Deficiencies immediately corrected by the operator are not recorded, except when such corrections are made by replacing parts which constitute repairs above the operator maintenance level. Such repairs will be recorded as organizational maintenance.

**Section III. TROUBLESHOOTING**

**4-9. Purpose and Scope**

Troubleshooting is a systematic isolation and remedy of malfunctions and defective components by

means of symptoms and tests. The tests and remedies provided herein are governed by the scope of the level of maintenance of the barometer.

Table 4-3 lists the applicable sequence in performing a step-by-step procedure for locating and replacing the defective components of the barometer. Where possible, reference has been made to the applicable paragraph for repair or correction of the fault. Where no paragraph is directly applicable, methods for correcting

the trouble TM 9-6685-202-14 are given in the chart itself.

**4-10. Troubleshooting Chart**

Table 4-3 is a list of possible troubles and malfunctions, the defective condition which may be causing the trouble and the remedy for correcting the condition.

**Table 4-3. Troubleshooting Chart**

Trouble	Probable Cause	Remedy
Lamp fails to light	Improperly inserted batteries.	Withdraw battery tube and replace batteries properly (para 3-4).
	Weak batteries	Withdraw battery tube and remove dry cells. Replace with fresh ones. Use BA-30, type C.
	Bulb loose or burned out.	Tighten or replace bulb (para 4-5f).
Barometer reads low	Air bubble in tube	Remove air bubble (para 4-5d).
	Mercury lost from barometer.	Check mercury level (para 4-5a).
	Moisture in tube	Remove moisture (para 4-5e).
Mercury in the tube moves in jumps as the pressure is varied smoothly.	Air bubble in connecting passage.	Same as removing moisture (para 4-5e).
Constant applied correction variation from given values.	Applied correction vernier scale not properly set.	Loosen the two applied correction vernier mounting screws. Set vernier to read given value. Tighten screws.
Disagreement of applied correction scale readings with values given in table 4-2	Dirt in sighting ring slide.	Blow out sighting ring slide with compressed air.

**Table 4-3. Trouble Shooting Chart-Continued**

Trouble	Probable Cause	Remedy
Applied correction scale errors large at midrange.	Cam bar bent more than 0.001 inch.	Return to depot maintenance shop for repair.
Instrument does not read 0.1 mm (0.004 inch) with tube and cistern at same pressure.	Improperly leveled	Level instrument (para 3-5).
	Incorrect amount of mercury.	Check mercury level (para 4-5a).
Instrument can be pulled below zero with vacuum on cistern and tube evacuated.	Improperly leveled	Level instrument (para 3-5).
	Incorrect amount of mercury in cistern.	Check mercury level (para 4-5a).
	Improperly evacuated tube.	Reevacuate tube (para 3-5).

**Section IV. CORRECTIVE MAINTENANCE**

**4-11. General**

This section includes instructions for the disassembly and assembly of the type A-1 and the type A-1 modified barometer, vacuum pumps 4310-203-3057 and 4931-929-8403, and constant vacuum regulator 6685-306-5604 as far as necessary to replace spare parts authorized in appendix C. The exploded views in this section show the sequence of disassembly. The parts illustrated are keyed by number callouts to a table of established nomenclature accompanying each figure.

**4-12. Disassembly**

KEY to fig. 4-3

- 1. Evacuation manifold
- 2. Screw, machine MS-35207-261
- 3. Clamp, loop, plastic MS-25281-F6
- 4. Union, reducing 7913085
- 5. Sleeve, top cap HIC 10-00-13
- 6. Screw, cap, socket head HIC 6-32 x 1/4
- 7. Tubing, plastic HIC 3/16 OD 1/16 ID x 1 1/4
- 8. Nipple, tube evacuating HIC 10-00-11A
- 9. Disc, top mounting HIC 10-00-14-C

- 10. Tube, barometer (includes valve subassembly) HIC 10-00-15-C
- 11. Screw, cap, socket head HIC 10-32 x 3/4
- 12. Block HIC 10-30-16-B
- 13. Setscrew HIC 4-40 x 1/8
- 14. Screw, cap, socket head, HIC 4-40 x 1/2
- 15. Washer, flat HIC No. 4
- 16. Clamp, cable HIC 1/8 in. dia
- 17. Screw, cap, socket head HIC 4-40 x 3/8
- 18. Jack, tip, light source HIC 12-A-1055
- 19. Vernier slide assembly
- 20. Holder, thermometer HIC 10-41-03-A
- 21. Screw, cap, socket head HIC 4-40 x 3/8
- 22. Thermometer HIC 10-41-01-A
- 23. Insert, clay block (commercial)
- 24. Bar, cam HIC 10-30-01-C
- 25. Stud, cam bar HIC 10-30-02-B
- 26. Screw, cap, socket head HIC 4-40x3/4
- 27. Washer, flat HIC No. 4
- 28. Washer, flat HIC 10-30-30
- 29. Scale, HIC 10-30-19-B (7913097-1)
- 30. Screw, cap, socket head HIC 4-40x 3/8

lg



- 31. Washer, flat HIC No. 4
- 32. Rod, adjusting HIC 10-30-09-A
- 33. Bracket, adjusting HIC 10-30-08-B
- 34. Nut, adjusting HIC 10-30-07-A
- 35. Washer, spring HIC 10-30-29
- 36. screw, cap, socket head HIC 4-40 x 3/8
- 37. Micrometer 7913326
- 38. Mount, block, gage 7913096
- 39. Screw, cap, socket head MS-16995-30
- 40. Cistern base assembly
- 41. Platform assembly HIC 10-50-00-A

- 42. Screw, cap, socket head HIC 5/16-24 x 1/2
- 43. Rod, thermometer HIC 10-40-01-A
- 44. Rod, scale HIC 10-30-17-B
- 45. Screw, cap, socket head HIC 1/4-28 x 1 1/4
- 46. Screw, cap, socket head HIC 5/16-24 x 1
- 47. Trap, glass 7913095
- 48. Reducer, flareless tube 7913082

**NOTE**

The key numbers shown below in parenthesis refer to figure 4-3.

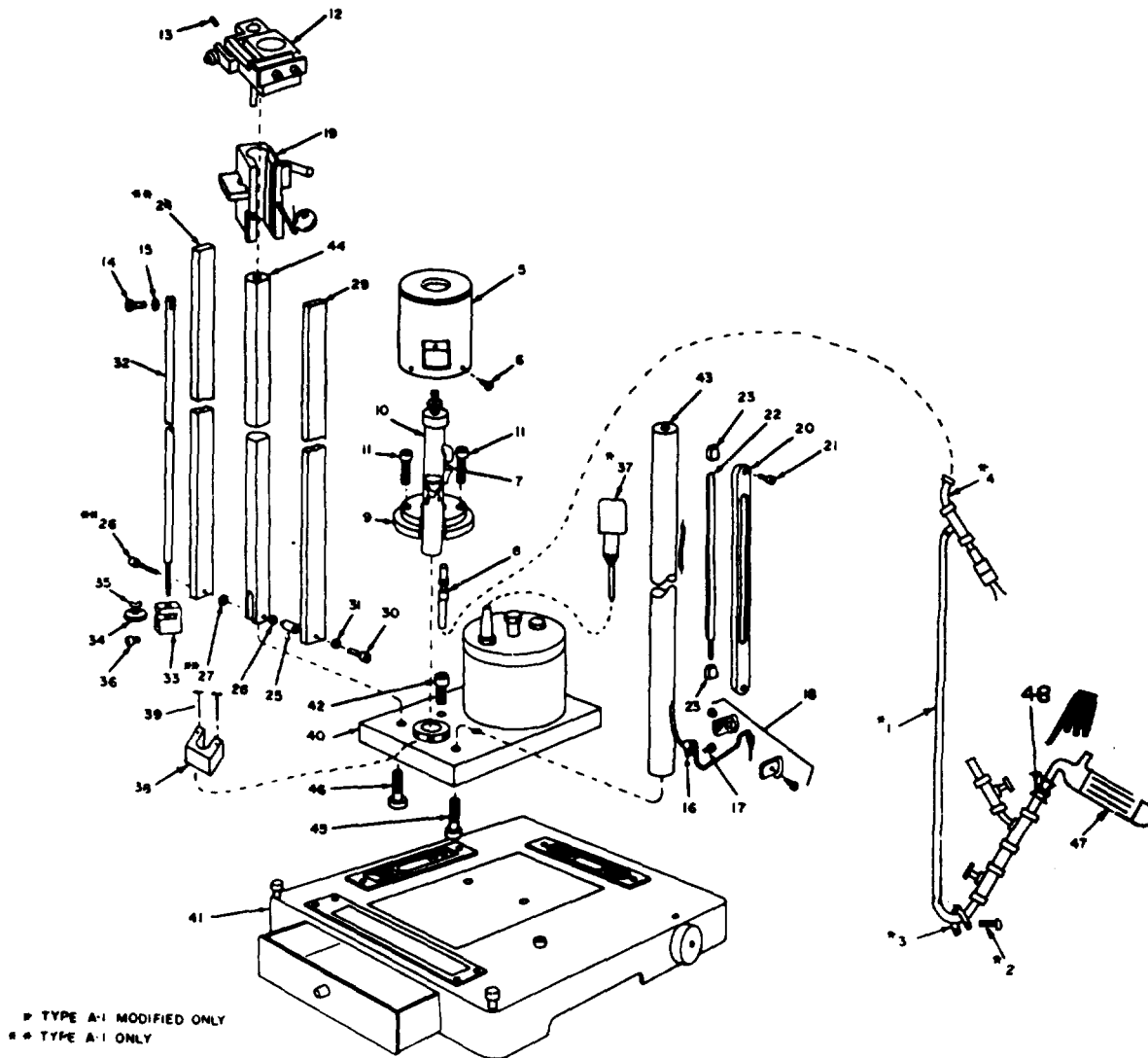

MI (C) 6685- 202-14-4-3

**Figure 4-3. Removal of subassemblies.**

a. *Removal of Subassemblies.* Place the barometer on a clean working surface and proceed as follows:

**NOTE**

Steps (1), (18), and (19) below pertain to the type A-1 modified barometer only.

(1) Remove evacuation manifold (1) and glass trap (47) by removing screw (2), clamps (3), and nut on union (4).

(2) Remove top cap sleeve (5) by removing three socket head cap screws (6).

**NOTE**

**Do not remove top cap assembly unless it is to be replaced.**

(3) Disconnect plastic tubing (7) from glass stem on side of barometer tube.

(4) Unscrew tube evacuating nipple (8) from top mounting disc (9).

(5) Unlock barometer tube (10) by loosening gland nut on cistern base.

(6) Lift barometer tube out of gland nut, slide tube through slot cut in top mounting disc (9), and remove from barometer.

(7) Remove top mounting disc (9) by removing two socket head cap screws (11).

(8) Free block (12) by removing setscrew (13), socket head cap screw (14), and fat washer (15).

(9) Slide block off the scale rod.

(10) Remove cable clamp(16) by removing socket head cap screw (17).

(11) Unplug light source tip jack (18) from receptacle on platform.

(12) Carefully slip vernier slide assembly (19) off the scale rod.

(13) Do not remove thermometer (22) or its holder unless it is defective. If it is necessary to replace the thermometer, remove thermometer holder (20) by removing two socket head cap screws (21) and remove thermometer from clay block inserts (23) in which it is imbedded.

(14) On the type A-1, remove cam bar (24) by removing cam bar stud (25) secured by socket head cap screw (26) and flat washers (27) and (28).

(15) Remove scale (29) secured to scale rod by two socket head cap screws (30) and flat washers (31).

(16) Unscrew adjusting rod (32) from adjusting bracket (33) and recover adjusting nut (34) and spring washer (35).

(17) Remove adjusting bracket (33) by removing socket head cap screw (36).

(18) Remove micrometer (37) from cistern lid.

(19) Remove gage block mount (38) by removing two socket head cap screws (39).

(20) Separate cistern base assembly (40) from platform assembly (41) by removing two socket head cap screws (42) set in the top of the cistern base assembly.

**NOTE**

Older barometers already in service use the thermometer rod as one current path to the light bracket, and the other members of the barometer serve as a ground return. Therefore, in disassembling such models, carefully preserve the three insulator washers that insulate the thermometer rod from the top mounting disc and the cistern base which are in contact with the grounded items. The light source tip jack electrical lead on older models is attached by means of a terminal lug and screw to the bottom of the thermometer rod. In requisitioning a replacement "light source tip jack" indicate the model of barometer under repair.

(21) Remove the thermometer rod (43) and the scale rod (44) by removing the socket head cap screws (45) and (46) attaching the rods from the underside of the cistern and base assembly.

(22) The barometer is now disassembled into its subassemblies which can in turn be further disassembled for utilization of authorized repair parts according to instructions in the following subparagraphs.

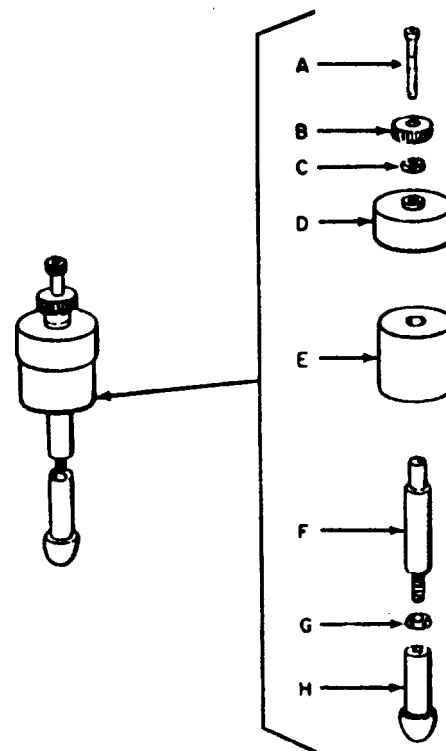

MI (C) 6685-202-14-4-4

Figure 4-4. Disassembly of valve subassembly.

KEY to fig. 4-4

- A. Screw, cap, socket head HIC 4-40 x 3/4
- B. Nut, locking HIC 10-20-16
- C. Washer, steel HIC No. 4
- D. Washer, valve HIC 10-00-08-A
- E. Diaphragm HIC 10-00-09-A
- F. Stud, valve HIC 10-00-06
- G. Nut, stainless steel HIC 4-40
- H. Valve, ball HIC 10-00-07

**NOTE**

**The key letters shown below in parenthesis refer to figure 4-4.**

*b. Valve Subassembly (Type A-1 Only) (Fig. 4-4).*

To disassemble the valve subassembly for purposes of cleaning, lift valve subassembly out of barometer tube, remove socket head cap screw (A), to separate locking nut (B), steel washer (C), valve washer (D), and diaphragm (E) from valve stud (F). Unscrew ball valve (H) and nut (G) from valve stud (F).

**NOTE**

**The valve assembly is precision machined to match a particular barometer tube. If the barometer tube has been broken, a new valve subassembly will be supplied with the replacement tube. Do not interchange barometer tubes and valve subassemblies.**

KEY to fig. 4-5

- 1. Screw, cap, socket head HIC 4-40 x 3/8
- 2. Nut, adjusting HIC 10-20-16
- 3. Screw, correcting HIC 10-30-06-B
- 4. Screw, cap, socket head HIC 4-40 x 3/8
- 5. Washer, flat HIC No. 4
- 6. Screw, cap, socket head HIC 4-40 x 1/2
- 7. Washer, fiat HIC No. 4
- 8. Washer, lock HIC No. 5
- 9. Nut, adjusting HIC 10-20-16
- 10. Eccentric, correcting HIC 10-30-03
- 11. Setscrew HIC 4-40 x 1/8
- 12. Bracket, correcting screw HIC 10-30-05-B
- 13. Stud, correcting screw bracket HIC 10-30-
- 14. Nut, flexlock HIC No. 4-40
- 15. Index, temperature HIC 10-30-10-B
- 16. Screw, cap, socket head HIC 4-40 x 3/8
- 17. Arm, camrod HIC 10-30-13-B
- 18. Setscrew, socket head HIC 4-40 x 1/8
- 19. Scale, temperature and gravity HIC 10-30-
- 20. Screw, round head HIC 3-56 x 3/16
- 21. Washer, fiat HIC No. 3
- 22. Block HIC 10-30-16-B

31

15

**NOTE**

**The key numbers shown below in parenthesis refer to figure 4-5.**

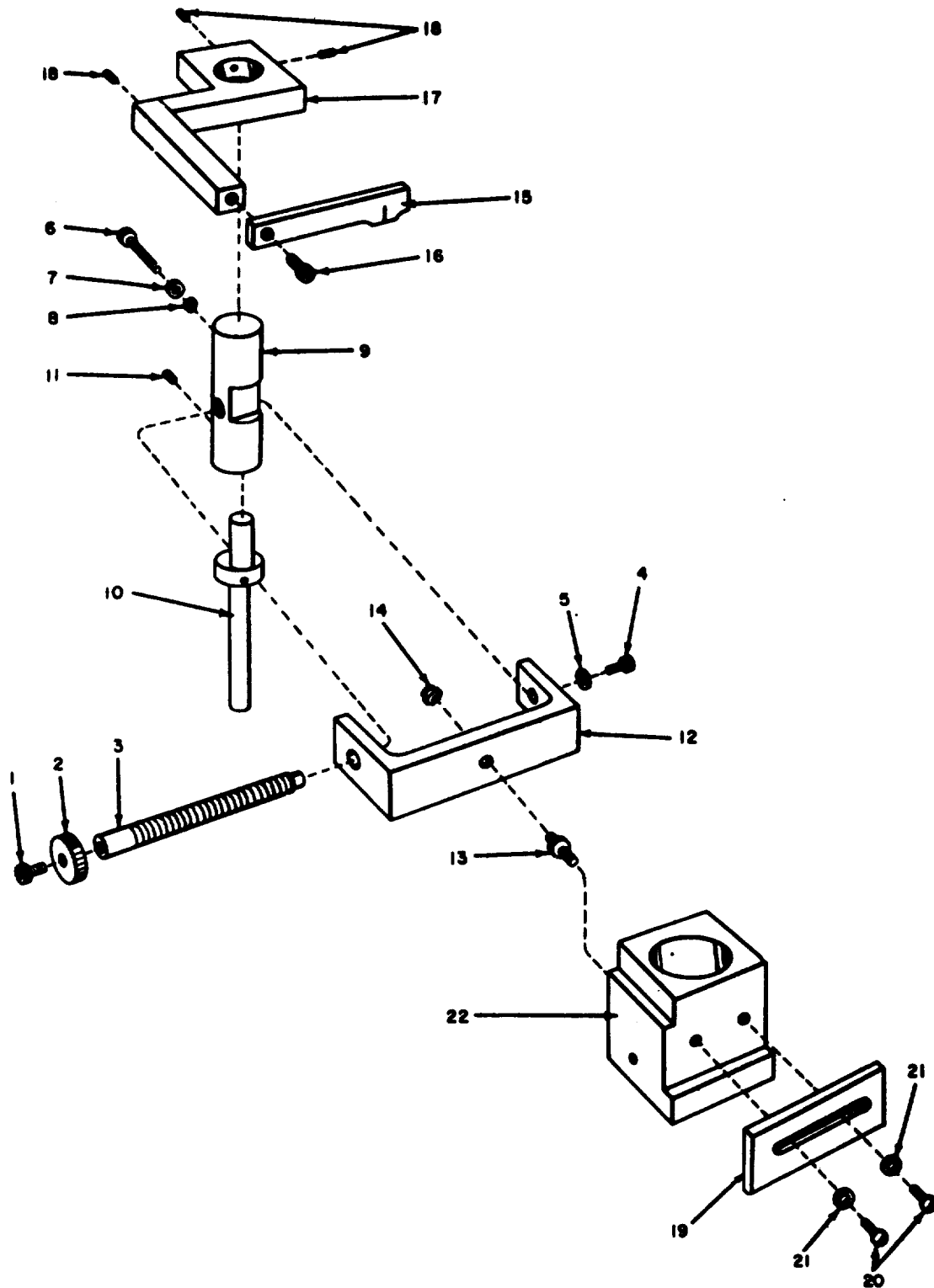

MI(C) 6685 202 14 4-5

Figure 4-5. Disassembly of temperature and gravity scale assembly.

c. *Temperature and Gravity Scale Assembly (Type A-1 Only) (Fig. 4-5).* Perform the following steps to disassemble the temperature and gravity scale assembly for utilization of authorized replacement parts.

(1) Remove socket head cap screw (1), adjusting nut (2) and correcting screw (3) by removing cap screw (4) and flat washer (5).

(2) Remove correcting eccentric (10) from adjusting nut (9) by removing set screw (11).

**NOTE**

**Older barometers already in service employ a different type of correcting nut than the model covered in this manual. These correcting nuts have a socket head screw (6), flat washer (7), and lockwasher (8) installed in a tapped hole passing through the diameter.**

(3) Remove correcting screw bracket (12) which is secured to block (22) by removing correcting screw bracket stud (13) and flexlock nut (14).

(4) Remove temperature index (15) by removing socket head cap screw (16).

(5) Remove arm (17) by removing setscrews (18)

(6) Remove temperature and gravity scale (19) by removing round head screws (20) and flat washers (21) from block (22).

KEY to fig. 4-6

1. Bracket, adjusting rod clamping HIC 10-20-04
2. Screw, cap, socket head HIC 4-40 x 3/4
3. Nut, locking HIC 10-20-16
4. Bushing, clamp HIC 10-20-15
5. Screw, cap, socket head HIC 4-40 x 1/4.

6. Spring, correcting lever bracket HIC 10-30-23-A
7. Screw, correcting lever HIC 10-30-25-A
8. Bracket, cam follower HIC 10-30-21-A and follower HIC 10-30-26
9. Pin, dowel, cam follower HIC 10-30-32
10. Pin, correcting lever HIC 10-20-23
11. Pin, correcting HIC 10-20-14-A
12. Lever, correcting HIC 10-20-11
13. Screw, correcting lever HIC 10-20-10B
14. Vernier HIC 20-10B
15. Screw, machine, fillister head HIC 0-80NF-2 x 1/8
16. Lamp (No. 323) 6240-155-7864
17. Bracket, light HIC 10-21-01
18. Ring, sighting HIC 10-20-09
19. Screw, machine, fillister head HIC 0-80 NF-2 x 3/32
20. Screw, machine, fillister head HIC 0-80NF-2X32.
21. Slide, sighting ring HIC 10-20-17-B
22. Strip, contact HIC 10-20-20-A
23. 3crew, machine, fillister head HIC 0-80NF-2X3/32
24. Strip, contact insulating HIC 10-20-21-A
25. Screw, cap, socket head HIC 4-40 x 3/16
26. Magnifier HIC 81-26-05
27. Post, magnifier HIC 10-20-07-A
28. Screw, cap, socket head HIC 4-40 x 1/4
29. Strip, vernier HIC 10-20-24
30. Screw, machine, fillister head HIC 0-80NF-2 x 1/8
31. Slide, vernier HIC 10-20-18

**NOTE**

**The key numbers shown below in parenthesis refer to figure 4-6.**

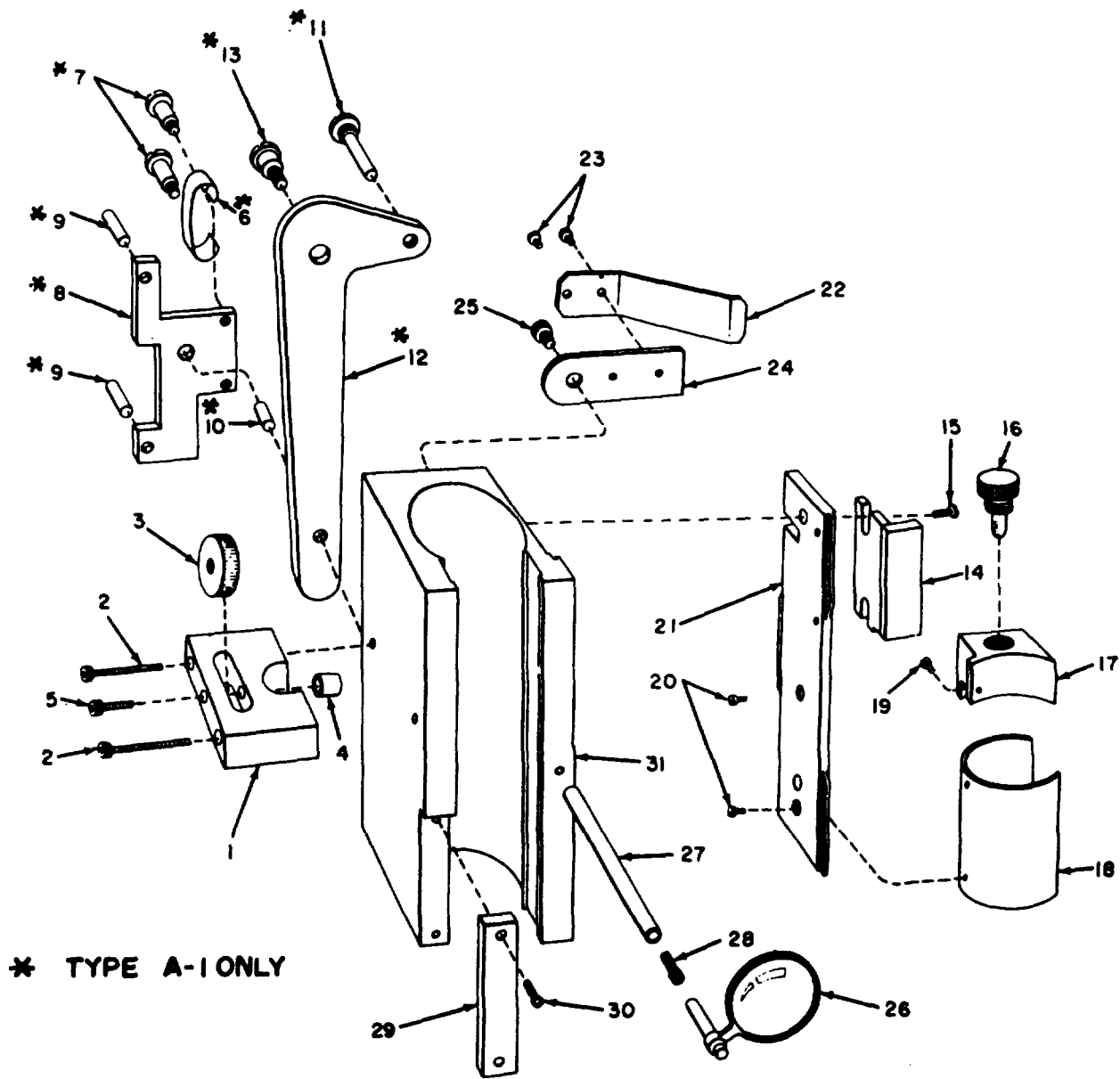

\* TYPE A-1 ONLY

MI(C) 6685-202-14-4-6

Figure 4-6. Disassembly of vernier slide assembly.

d. *Vernier Slide Assembly.* Perform the following steps to disassemble the vernier slide assembly for utilization of authorized replacement parts.

(1) If it is desired to replace electrical lead, tip jack, or light bracket (17), unsolder electrical lead from light bracket, otherwise leave solder in place.

(2) Remove adjusting rod, clamping bracket (1) from the side of vernier slide by removing socket

head cap screws (2). Release locking nut (3) and clamp bushing (4) by unscrewing socket head cap screw (5).

**NOTE**

**Steps (3) through (5) below pertain to the type A-1 only.**

(3) Remove correcting lever bracket spring (6) secured by two correcting lever screws (7).

(4) Remove cam follower bracket (8) and pins (9), (10), and (11) from correcting

lever (12).

(5) Remove correcting lever (12) from vernier slide (31) by removing correcting lever screw (13).

(6) Pull the sighting ring slide (21) and attached items out of the grooves on the vernier slide.

(7) Remove vernier (14) secured by two fillister head machine screws (15).

(8) Remove lamp (16) from light bracket (17).

(9) Remove light bracket (17) from sighting ring (18) by removing fillister head machine screw (19).

(10) Remove sighting ring (18) secured by two fillister head machine screws (20) from sighting ring slide (21).

(11) Remove contact strip (22) secured by two fillister head machine screws (23) and contact insulating strip (24) secured by one socket head cap screw (25).

(12) Pull magnifier (26) out of magnifier post (27) and remove post by removing socket head cap screw (28).

(13) Remove vernier strip (29) secured by two fillister head machine screws (30) to vernier slide (31).

KEY to fig. 4-7

1. Nut, gland HIC 10-10-06-B
2. Washer, tube cup HIC 10-10-17-A
3. Packing O-ring, hydraulic HIC 10-1018-A
4. Packing, O-ring, tube cushion HIC 1010-22
5. Nipple subassembly HIC 10-11-00
6. Gasket HIC 10-10-12-A
7. Plug, shipping HIC 10-10-01-A
8. Gasket HIC 10-10-12-A
9. Lid, cistern HIC 10-10-11-B
10. Gasket, cistern HIC 10-10-10-C
11. Cistern HIC 10-10-13-B
12. Nut, cistern HIC 10-10-03-A
13. Gasket HIC 10-10-12-A
14. Stud, cistern HIC 10-10-02-A
15. Screw, stop HIC 10-10-05
16. Screw, mercury locking HIC 10-10-04
17. Base, barometer HIC 10-10-14-B

**NOTE**

**Key numbers shown below in parenthesis, refer to figure 4-7.**

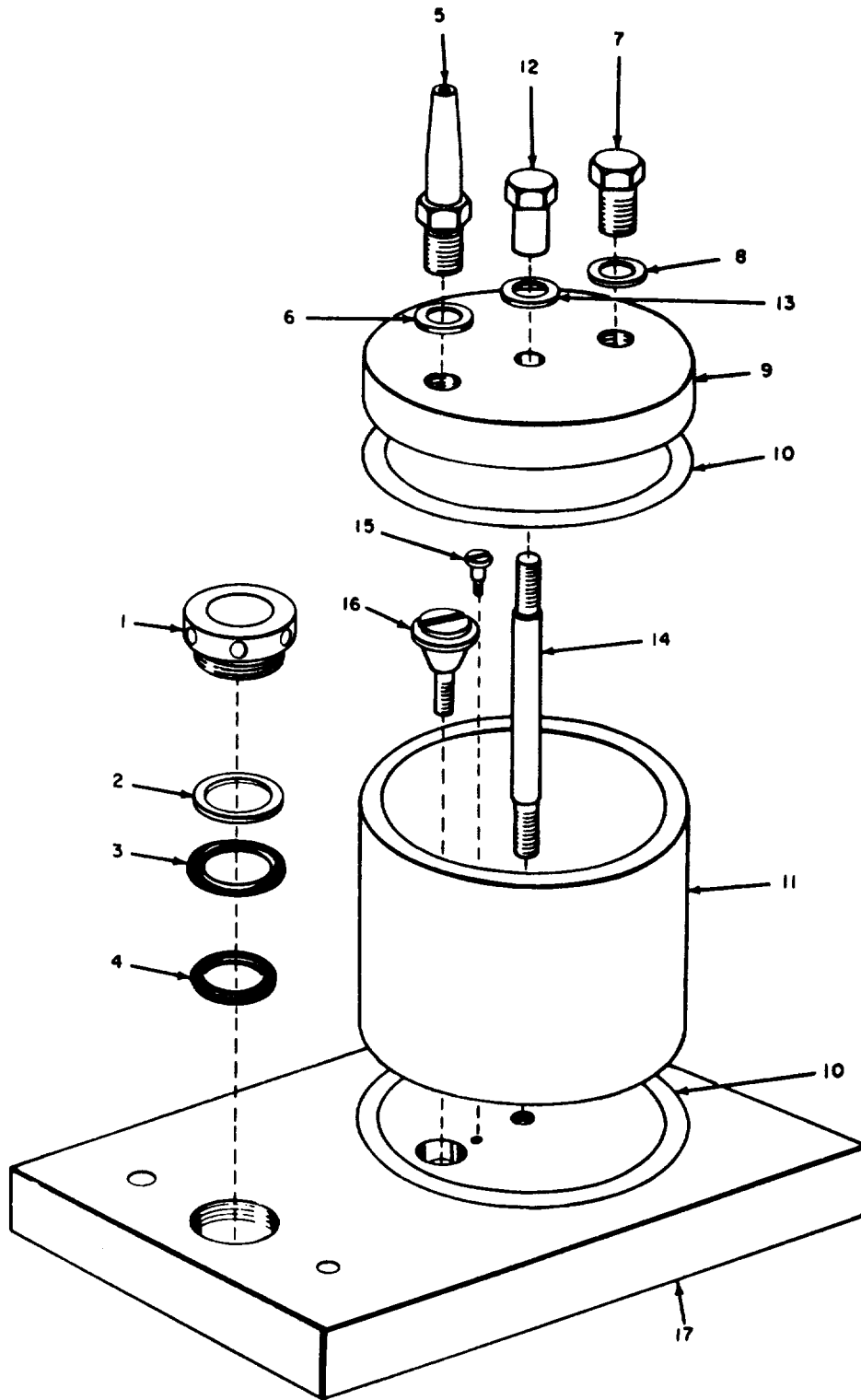

MI (C)6685-202-14-4-7

Figure 4-7. Disassembly of cistern base assembly.



e. *Cistern Base Assembly.* Perform the following steps to disassemble the cistern base assembly for utilization of authorized replacement parts:

(1) Remove gland nut (1) from the barometer base and recover tube cup washer (2), hydraulic O-ring packing (3), and tube cushion O-ring packing (4).

(2) Unscrew nipple subassembly (5) from cistern lid (9), recovering gasket (6).

(3) Unscrew shipping plug (7) from cistern lid, recovering gasket (8).

(4) Remove cistern lid (9), cistern gaskets (10), and cistern (11) by removing cistern nut (12) and gasket (13) from top of cistern stud (14). Remove cistern stud from barometer base.

(5) Remove stop screw (15) and mercury locking screw (16) from barometer base (17).

KEY to fig. 4-8

1. Cover, level HIC 10-50-00-A
2. Screw, machine, binding head HIC 4-40x 1/4
3. Plaster (Commercial)
4. Level, bubble HIC 10-55-01
5. Screw, leveling HIC 10-50-12-A
6. Cover, calibration HIC 10-50-21
7. Chart, calibration HIC 10-50-22
8. Screw, machine, binding head HIC 4-40 x 1/4
9. Drawer HIC 10-50-19
10. Knob, drawer HIC 10-50-18
11. Screw, machine, binding head HIC 6-32 x 1/4

12. Screw, battery HIC 10-60-04
13. Tube, battery case HIC 10-53-01-A
14. Plug, battery case HIC 10-53-02
15. Screw, contact HIC 10-52-03
16. Nut, hexagon HIC No. 5-40
17. Nut, hexagon HIC No. 5-40
18. Spring, contact HIC 10-52-04
19. Bushing, contact HIC 10-52-03
20. Terminal, wire, solderless (Commercial)
21. Wire, PVC insulated AWG No. 32, 12 in. lg (Commercial)
22. Clamp, cable HIC 1/8 in. wire size
23. Screw, steel HIC 4-40 x 1/4
24. Switch, pushbutton HIC 17-B-203
25. Nut, binding 7/16-24-NF
26. Receptacle assembly HIC 13N12935

- A -Receptacle HIC 13N12935A
- B -Nut HIC 13N12935B
- C -Insulator HIC 13N12935C
- D -Nut, insulator HIC 13N12935D
27. Plate, identification HIC 10-50-23
28. Screw, machine, socket head HIC 2-56 x 3/16
29. Platform HIC 10-50-17

**NOTE**

**The key numbers shown below in parenthesis refer to figure 4-8.**

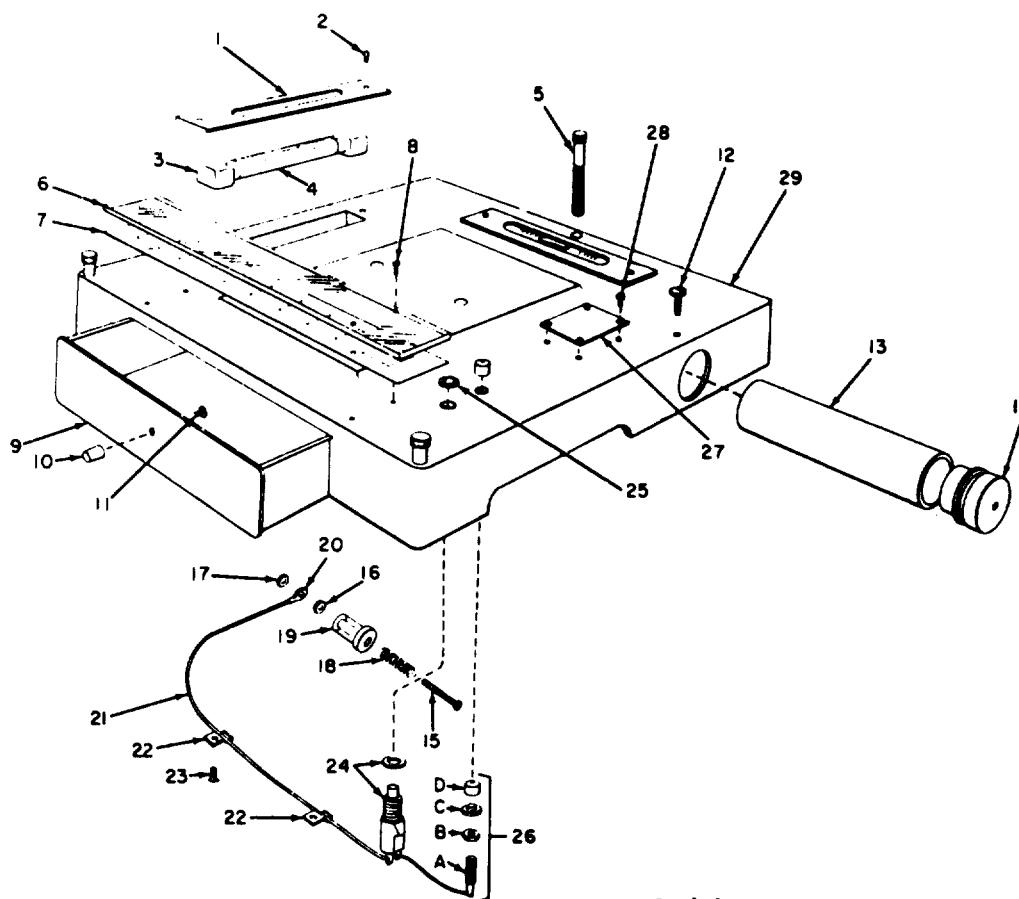

MI(C) 6685-202-14-4-8

Figure 4-8. Disassembly of platform assembly.

f. *Platform Assembly.* Perform the following steps to disassemble the platform assembly for utilization of authorized replacement parts.

(1) If it is necessary to replace either of the two levels, remove level cover (1) by removing two binding head screws (2). Chip out plaster (3) in which the level is set and remove bubble level (4).

(2) Remove three leveling screws (5) from the platform.

(3) Remove calibration cover (6) and calibration chart (7) by removing four binding head machine screws (8).

(4) Remove drawer (9), and remove drawer knob (10) secured by binding head machine screw (11).

(5) Remove battery screw (12), slide battery case tube (13) out of its place in the base, and remove battery case plug (14).

(6) Remove contact screw (15), hex nuts (16) and (17), recover contact spring (18), and contact bushing (19) from its mounting on an internal rib of the platform to free electrical items which are connected to solderless wire terminal (20) and insulated wire (21).

(7) Remove two cable clamps (22) secured to under side of platform by screws (23).

(8) Remove push button switch (24) by removing binding nut (25).

(9) Remove receptacle assembly (26) which is composed of receptacle (A), nut (B), insulator (C), and insulator nut (D) from the underside of the platform.

(10) Do not remove identification plate (27) unless illegible or damaged, to avoid losing identity of barometer. If nameplate is to be replaced, remove four socket head machine screws (28) attaching it to platform (29).

## KEY to fig. 4-9

1. Cover, assembly CSC 9200 RW
2. Screw, machine round head
3. Gasket, cover CSC 9200 RM
4. Nipple, intake
5. Bolt, machine
6. Inlet, tank
7. Bolt, machine
8. Ring, seal, carbon CSC 9200RS
9. Seal assembly, shaft CSC 9200RL
10. Shaft CSC P60681
11. Pulley
12. Ring, retaining, CSC 9200RC
13. Ring, retaining, CSC 9200RT
14. Bearing, thrust CSC P60692
15. Valve, drain
16. Case, pump CSC P60007
17. Center plate CSC P60007
18. Stripper bolt
19. Side plate CSC P60007
20. Plate, valve retainer CSC 9200RN
21. Key, shaft CSC P65008
22. Bolt, machine
23. Pin, straight, headless
24. Bolt, machine
25. Intake ring CSC 9200RB
26. Bolt, machine
27. Exhaust ring CSC 9200RA
28. End plate CSC P60008
29. Bolt, machine, end plate
30. Rotor, CSC P60003
31. Pin, spring CSC P63003
32. Ball, valve CSC 9200RP
33. Vane, exhaust CSC P60599
34. Bushing, spring arm CSC P63002
35. Stop, vane CSC P60011
36. Vane, intake CSC P60598
37. Arm, spring lever CSC P60004
38. Spring, vane, CSC 9200RK

**Note**

**The key numbers shown below in parenthesis refer to figure 4-9.**

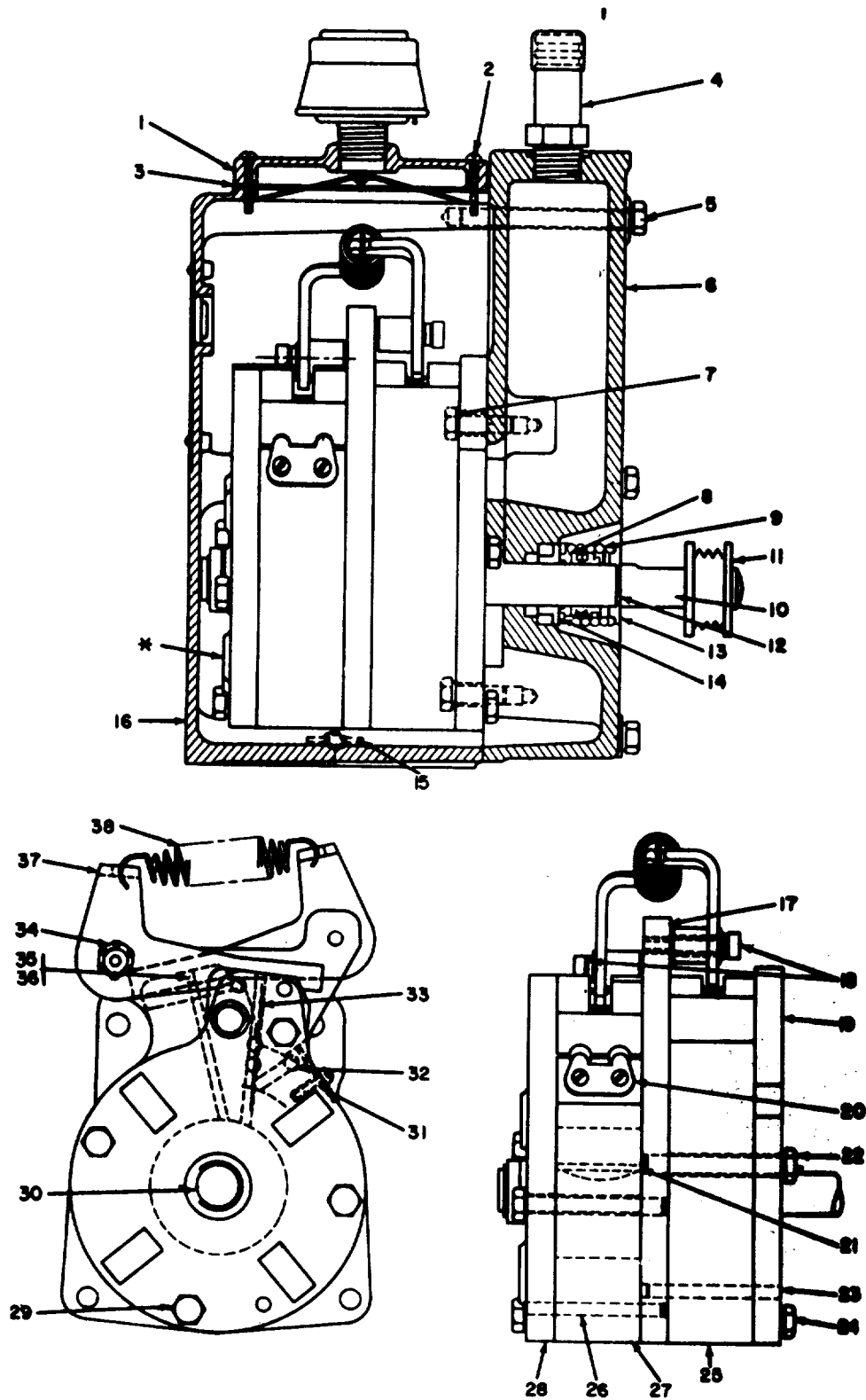

\* PUMP ASSEMBLY (PROPRIETARY ITEM)

MI (C) 6685-202-14-4-9

Figure 4-9. Disassembly of vacuum pump, 4310-203-3057.

*g. Vacuum Pump 4310-203-3057, Replacement of Springs, Vanes, or Pump Release.* If the pump fails to function, the trouble usually can be attributed to a broken spring, sticking vanes, or worn valve release.

(1) To inspect spring and vanes, remove four machine screws, (2) and top plate of cover assembly (1). A broken spring will prevent vanes from riding snugly against rotor during cycle of operation, thus causing inefficiency of operation.

(2) To remove vanes (33 and 36) for inspection, release spring (38) and remove spring lever arms (37) and stripper bolts (18). Turn pump shaft several revolutions by hand and note how much of the vane extends beyond the pump housing. In removing a vane, grasp only that portion which extends beyond the pump housing with sharp nosed pliers. Use extreme care to be sure that any portion of the vane which fits into the vane slot is not scored or nicked in any way. Remove one vane at a time, and under no circumstances allow the vanes to become interchanged or reversed in position. Polish vanes slightly with the finest grade of polish paper if they appear to be corroded. No metal should be removed during polishing process.

(3) Replace vanes (33 and 36) in their original vane slots. Make certain that they have not been interchanged and are in their original position. Install spring lever arms (37). Tighten stripper bolts (18). Bring lever arms into contact with vanes. Install vane spring (38).

(4) Rotate shaft pulley clockwise several revolutions.

(5) Observe that the vanes move freely and easily in the vane slots and remain in contact with rotor (30).

(6) Check that top cover gasket (3) is in good condition; replace if necessary. Fasten cover assembly (1) and gasket to pump case assembly with four round head screws (2).

#### NOTE

**The key numbers shown below in parenthesis refer to figure, 4-9, except when otherwise indicated.**

*h. Vacuum Pump 4310-203-3057, Replacing Shaft Seals.* To replace shaft seal assembly (9) proceed as follows:

(1) Remove belt and pulley (11) from pump.  
 (2) Depress retaining ring (13) and remove retaining ring (12).

(3) Remove shaft seal assembly (9).

(4) Before replacing a seal assembly, apply a thin film of oil to shaft (10). Also, apply a thin film of oil to the inner surface of shaft seal assembly (9). Exercise care that inner surface of carbon seal ring (8) is not damaged. Push seal back so that it contacts end plate of shaft seal assembly (9). Force spring and retainer washer over groove in shaft, and replace retaining ring (12).

(5) Replace pulley (11) on shaft and install belt on pulley. Adjust belt tension by moving motor on base.

*i. Vacuum Pump 4310-203-3057, Disassembly Procedure.* Perform the following steps to disassemble the vacuum pump for utilization of authorized replacement parts:

(1) To replace exhaust valve retainer and ball valve, remove pump assembly from pump platform.

(2) Drain oil from case.

(3) Remove six machine bolts (5).

(4) Remove pump mechanism from pump case (16).

(5) Remove valve retainer plate (20) and valve balls (32) from exhaust ring (27).

(6) To replace end plate (28) or rotor (30), remove pulley (11) and shaft seal assembly (9) from shaft (10).

(7) Remove vane spring (38) and vanes (33 and 36).

(8) Remove retaining ring (12) from exhaust end of shaft.

(9) Remove machine bolts (29).

(10) Remove machine bolts (26) and lift end plate (28) from shaft. Pins should remain in exhaust ring assembly.

(11) Remove rotor (30) from shaft. Observe and note which face of rotor is in contact with end plate (28).

(12) Remove shaft key (21) from shaft.

(13) To remove side plate (19) and rotor, remove four machine bolts (22) which secure side plate to inlet tank.

(14) Remove four machine bolts (24) which secure side plate to intake ring (25).

(15) Lift side plate off pins (23) and shaft. Pins should remain in intake ring.

(16) Remove rotor (30) from shaft. Observe and note which face of rotor is in contact with side plate (19).

(17) Remove shaft key (21) from shaft.

(18) With keys removed, shaft (10) can be withdrawn from either end.

(19) Do not remove exhaust ring (27) or intake ring (25) from center plate (17) unless replacement of rings or center plate is necessary. Examine intake and exhaust rings and clean thoroughly while still assembled to center plate.

(20) Replace the pump motor if inspection shows that it does not operate properly.

KEY to fig. 4-10

1. Setscrew, pulley 5/16-18 x 1/2 WSC 2-01-6308
2. Pulley, WSC 41-2191
3. Seal, oil WSC 1401E
4. Gasket, seal WSC 41-0643
5. Key, WSC 41-0624
6. Shaft and retaining ring WSC 41-1060
7. Ring, retaining WSC 41-1150
8. Key, woodruff, WSC 41-0613
9. Screw, fillister head WSC 2-00-2705, steel 10-32 x 5/16
10. Legs, WSC 41-1049
11. Washer, rubber WSC 41-1267
12. Disc, glass WSC 41-1268
13. Washer, tension WSC 41-1266
14. Case, oil WSC 41-1047
15. Cap, dust WSC 41-1345
16. Gasket WSC 41-1052
17. Screw, hex head WSC 2-01-0332, steel 5/16-18 x 2
18. Washer WSC 41-2363
19. Plate, front WSC 41-1045
20. Rotor, WSC 41-1400
21. Valve, spring WSC 41-1239
22. Washer, brass, No. 10, WSC 2-71-0040
23. Screw, fillister head WSC 2-00-2705, steel, 10-32 x 5/16
24. Washer WSC 41-1056
25. Plug, WSC 41-1039
26. Plate, center WSC 41-1044

27. Washer, steel WSC 41-1285
28. Filter, air WSC 41-0890
29. Gasket, WSC 41-0383
30. Chamber, intake WSC 41-1048
31. Nipple, WSC 41-0920
32. Screw, hex head, WSC 2-01-0520, steel, 3/8-16 x 1 1/4
33. Plate, back WSC 41-1055
34. Shaft, end WSC 41-1255
35. Screw, fillister head, WSC 2-00-2708, steel, 10-32 x 1/2
36. Nut, hex, WSC 2-31-2521, steel, 3/8 x 16
37. Ring, outer WSC 41-2563
38. Rotor WSC 41-1041
39. Holder, spring WSC 41-1063
40. Spring, WSC 41-1304
41. Vane, WSC 41-1059
42. Screw, socket head, WSC 2-01-6112, steel, 1/4-20 x 3/4
43. Ring, inner, WSC 41-1042
44. Gasket, WSC 41-0056
45. Seal, WSC 41-0578
46. Cover, oil cover, WSC 41-1061
47. Screw, fillister head, WSC 2-10-2608, steel, 8-32 x 1/2
48. Screwstick, self-tapping, 1-72 x 1/8, WSC 2-09-1202
49. Plate, pump instruction, WSC 41-1936
50. Cap, oil drain, WSC 41-1166
51. Disc, WSC 41-1192
52. Fitting, brass WSC 41-1168
53. Screw, round head, WSC 2-01-5308, steel, 5/16-18 x 1/2

**NOTE**

The key numbers shown below in parenthesis refer to figure 4-10.

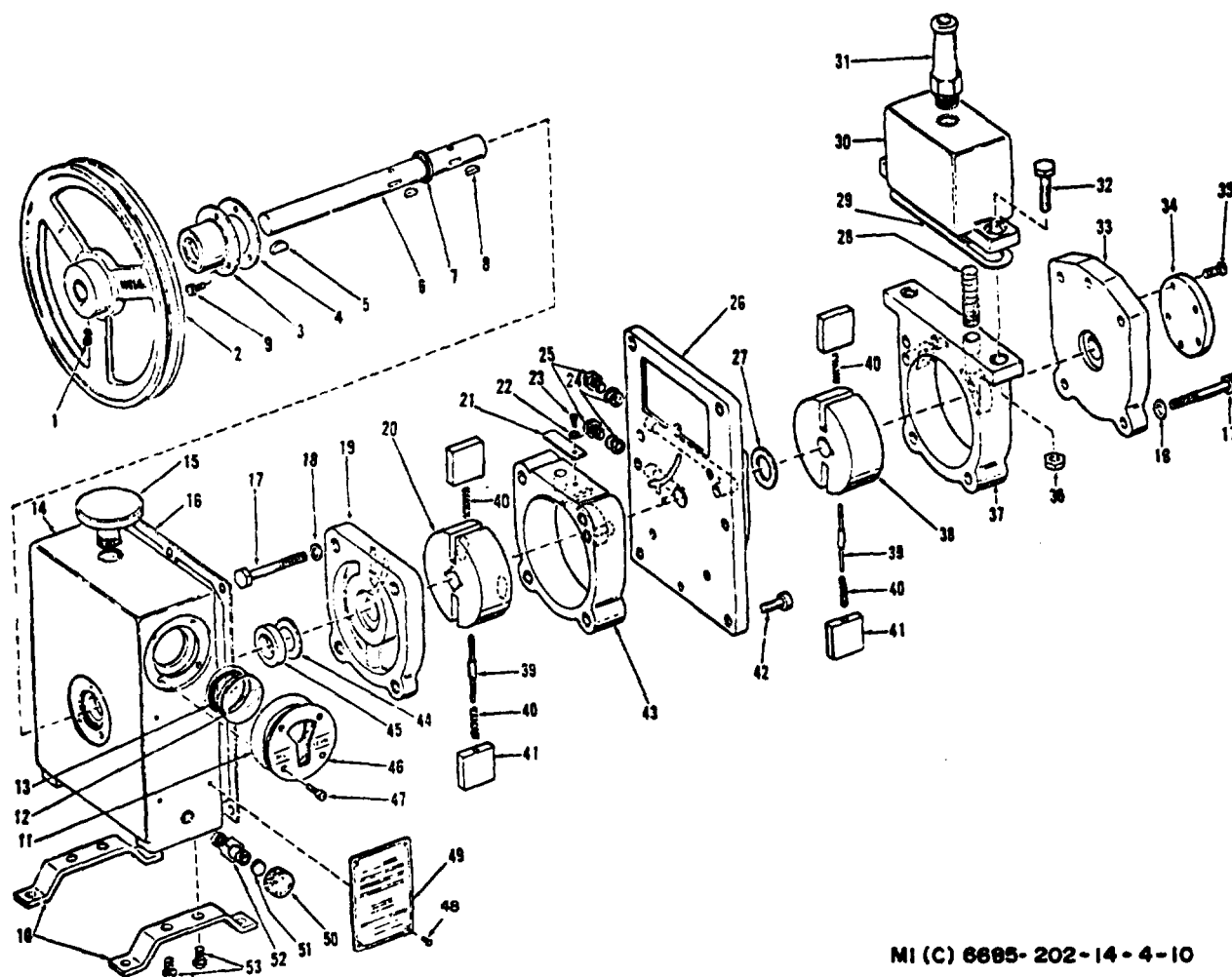

MI (C) 6685-202-14-4-10

Figure 4-10. Disassembly of vacuum pump 4931-929-8403.

*j. Vacuum Pump 4931-929-8403, Replacement of Springs, Vanes, or Pump Release.* If the pump fails to function, the trouble usually can be attributed to a broken spring or sticking vanes.

(1) To inspect the springs or vanes, remove screws from the belt guard and remove the guard. Remove the belt. Loosen pulley setscrew (1) and remove pulley (2).

(2) Remove oil drain cap (50) and drain oil from the case. Remove eight socket head screws (42) from center plate (26).

(3) Remove three fillister head screws (9) from oil seal (3) and remove seal (3) and gasket (4).

(4) Remove center plate (26), inner ring (43), outer ring (37), intake chamber (30), and back plate (33) assembly from case (14).

(5) Remove nine hex head screws (17) and washers (18) from front plate (19) and back plate (33) assembly.

(6) Remove inner and outer rings carefully to prevent vanes (41), springs (40), and spring holders (39) from jumping out of the rotor slots. Do not allow the vanes to be interchanged or reversed in position. Polish the vanes lightly with a fine grade of polish paper, if necessary, to remove corrosion. No metal should be removed during the polishing process.

(7) Reinstall spring holders (39), springs (40), and vanes (41) in their original slots, making certain that they have not been interchanged.

(8) Reinstall front and back plates (19 and 33) with screws (17) and washers (18).

(9) Reinstall center plate (26), intake chamber (30), front plate (19), back plate (33), inner ring (43), and outer ring (37)

using screws (42).

(10) Reinstall gasket (4) and oil seal (3) using screws (9).

(11) Reinstall pulley (2) and tighten setscrew (1).

(12) Reinstall the belt guard.

**NOTE**

**The key numbers shown below in parenthesis refer to figure 4-10.**

k. *Vacuum Pump 4931-929-8403, Replacing Shaft Seals.*

(1) Remove screws from the beltguard and remove the guard.

(2) Remove the belt.

(3) Loosen setscrew (1) and remove pulley

(2).

(4) Remove screws (9) and seal (3).

(5) Apply a thin film of vacuum pump oil to the shaft and inner surface of the replacement seal. Install seal (3) with screws (9).

(6) Reinstall pulley (2) and tighten setscrew

(1).

(7) Reinstall the belt guard.

KEY to fig. 4-11

1. Valve, vacuum pump WTI FU-3424

2. Packing, asbestos yarn WTI P-538-1/16 in.

3. Adapter, hose WTI CPH-500-1/4 in.

4. Screw, machine, socket head 1/4-20 x 1/2 WTI CPH-21772

5. Screw, machine, round head 8-32 x 1/2 WTI CPH-5988

6. Stud, handle WTI FP-5737

7. Handle WTI FP-5736

8. Washer WTI CPH 5663

9. Wheel, Crank WTI FP-8108

10. Seal WTI FP-8094

11. Bearing, thrust WTI FU-3881

12. Washer, facing WTI FP-8096

13. Washer, spring WTI FP-8097

14. Nut, locking, split WTI FP-8095

15. Screw, machine, round head 4-40 x1/4 WTI P-37633

16. Stud, tension WTI FU-3877

17. Spring, control WTI FU-3878

18. Nut, locking, split WTI FP-8095

19. Screw, round head 4-40 x 3/16 WTI P-27108

20. Housing, upper WTI FU 3876

21. Packing, preformed (O-ring) WTI P-36562

22. Bushing WTI FP-5738

23. Screw, machine, round head 8-32 x5/8 WTI CPN-3675

24. Washer, WTI P-11149

25. Spider, WTI FP-8098

26. Washer, lock WTI P-12850

27. Crossbar, WTI FP-5381

28. Retainer, spring WTI FP-5373

29. Spring, WTI FP-5372

30. Disc, valve WTI FP-7440

31. Retainer, seat WTI FP-7441

32. Spacer, WTI FP-7445

33. Nut, hexagon WTI P-9933

34. Valve inlet and tube WTI FU-3428

35. Bellows unit WTI FU-3427

36. Gasket WTI FP-7442

37. Seal, WTI FP-8101

38. Packing, preformed (O-ring) WTI P-26822

39. Washer, flat WTI CPN-2247

40. Nut, hexagon, 3/8-24 WTI CPN-13180

41. Wax, sealing WTI E-383

42. Screw, machine, flat head 6-32 x 1/2, WTI CPH-31438

43. Cap, WTI FP-8103

44. Inlet tube, WTI FU-3875

45. Gasket, WTI FP-8102

46. Packing, preformed (O-ring) WTI P-30066

47. Screw, machine, round head 8-32 X 3/8 WTI CPH-24184

48. Housing, lower WTI FP-8113

**NOTE**

**The key numbers shown below in parenthesis refer to figure 4-11.**



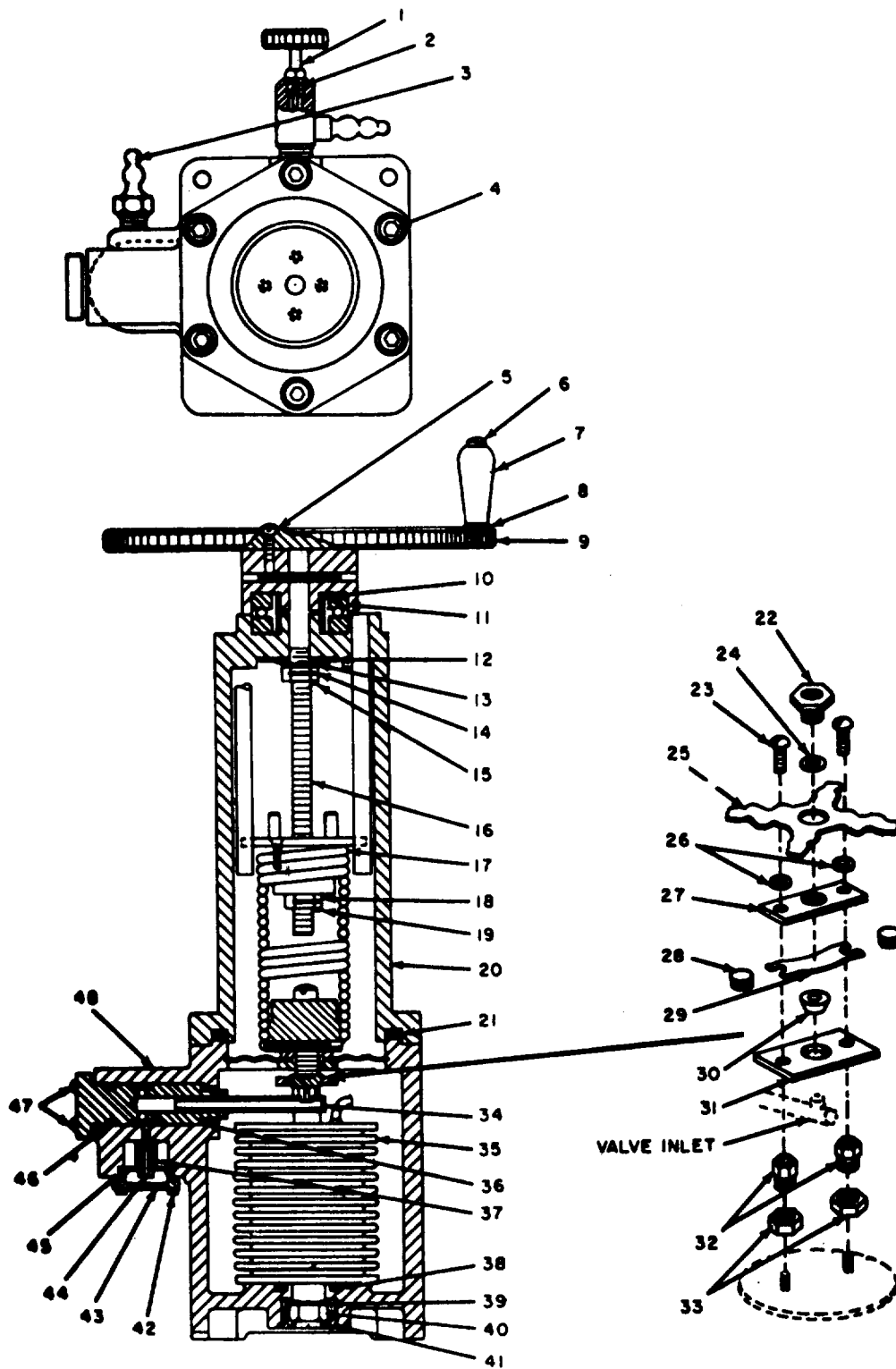

MI(C) 6685-202-14-4-11

Figure 4-11. Disassembly of constant vacuum regulator.

*l. Constant Vacuum Regulator, 6605-3065604, Valve Replacement*

Disassemble only those parts of the constant vacuum regulator that are necessary to effect repair or replacement of authorized parts.

(1) Do not remove the crank wheel assembly from the upper housing unless there are broken or damaged parts.

(2) Do not remove bellows unit (35) from lower housing (48) unless it is damaged and requires repair or replacement. Attempt to extend bellows by pulling on cross bar (27). If it moves easily, a leak is present and the bellows must be reworked or replaced.

(3) Inspect valve disc (30). If seating surface is scored, repair or replace disc.

(4) Replace packing in vacuum pump valve (1) with 1/16-inch asbestos yarn (2) and a lubricant such as vaseline when necessary.

(5) Replace any gaskets or O-rings which are not in good condition.

**NOTE**

**The key numbers shown below in parenthesis refer to figure 4-11.**

*m. Constant Vacuum Regulator, 6605306-5604, Disassembly.* Perform the following steps to disassemble the constant vacuum regulator for utilization of authorized replacement parts:

(1) On the upper housing, turn crank wheel assembly counterclockwise until it bears against internal stop.

(2) Remove six machine screws (4) which join the upper and lower housing. The O-ring preformed packing (21) should remain in the grooved ring of the upper housing. Loosen the upper housing.

(3) Grasp upper housing (20) and turn it in a counterclockwise direction. This will unscrew control spring assembly (17) from crossbar (27). Upper housing (20) and lower housing (48) will separate.

(4) To remove control spring (17) from the upper housing, loosen round head screw (19) in split locking nut (18) and remove the nut.

(5) Turn crank wheel (9) counterclockwise until the spring assembly is free of the housing.

(6) To remove the crank assembly from the housing, loosen machine screw (15) on split locking nut (14), and remove the locking nut, facing washer (12),

and spring washer (13). Withdraw the crank wheel shaft through the top of the housing.

(7) To remove the vacuum pump valve stem, unscrew the integral packing nut and then unscrew the stem. The asbestos packing (2) may be removed with a probe.

(8) Unscrew bushing (22) on the control valve assembly.

(9) Pry one leg of spider (25) out of the groove with a screw driver and remove the spider.

(10) Remove machine screws (23); this will separate the valve assembly from bellows unit (35).

(11) Remove four machine screws (47) on valve inlet and tube (34).

(12) Withdraw the valve inlet from lower housing (48).

(13) To separate bellows unit (35) from lower housing in the vacuum -actuated chamber, place a blade of steel approximately 2 in. by 2 in. by 1/8 in. thick between spacers (32). Be careful not to damage the lead pigtail.

(14) Turn the bellows counterclockwise to separate bellows unit (35) from lower housing.

**4-13. Cleaning**

Clean all parts that come in contact with mercury as follows:

a. Remove mercury from the barometer in accordance with paragraph 4-5b.

b. Remove the cistern micrometer. Wipe the shaft with a soft cloth or tissue and blow off lint and dust with clean compressed air. Place the micrometer in a clean, safe place until time for reassembly. No further cleaning of the micrometer is necessary.

c. Disassemble the barometer in accordance with paragraph 4-12.

d. Place all metal parts in a stainless steel or glass tray containing cleaning compound such as alconoc, calgonite, oakite, or bonami (FSN 7930-243-5940, 7930-5581111, or 7930-999-2417) and hot water.

e. Using brush FSN 7510-550-8446, scrub the parts thoroughly.

f. Using a small brush or pipe cleaner, swab out connecting passage and screw holes in the base plate. Brush all screw threads thoroughly.

g. Rinse all parts several times in hot

water and then in distilled or demineralized water.

h. Dry all parts with clean chamois skin MP/N KK-C-300.

**NOTE**

**A new (previously unused) chamois skin should be washed several times in detergent to remove tanning oils and rinsed thoroughly in clear water.**

i. Blow off excess water droplets with clean compressed air or rinse in high-grade acetone, if available.

j. Using a brush and cleaning compound, clean glass cistern in the same manner as described for metal parts.

k. Using cleaning rod 7913102 and a piece of cheesecloth FSN 8305-205-3496 or clean rag, scrub the barometer tube thoroughly.

l. Rinse glass parts thoroughly with hot water and finally with distilled water. Blow clean, dry air through tube until dry.

m. Reassemble the barometer in accordance with paragraph 4-14.

n. Wipe the scale and thermometer rods with a soft cloth containing a few drops of instrument oil MIL-L-

6085. Do not apply oil directly to the surface since even a small amount will catch dust.

**4-14. Assembly**

In general the reassembly of the individual subassemblies of the barometer will follow the reverse order of disassembly shown in figures 4-3 through 4-8. Individual operations that require particular care are presented below.

a. *Platform Assembly.* If either level has been removed, chip out all the old plaster from the level well in the platform and set the new level temporarily in blocks of oily clay. Adjust the replaced bubble level against a master indicator and when a level indication is obtained, set the level permanently in plaster of paris.

b. *Cistern and Base Assembly (Fig. 4-12).* Install a new tube cushion O-ring packing and large O-ring hydraulic packing. Press the O-ring press washer into the gland nut well in the barometer base. Apply a small quantity of sealant grease (Fisher Scientific Company, Part Number 14-637 or equal) to the lower two or three threads of the gland nut, being careful not to contaminate the other items. Screw the gland nut into the barometer base, but do not tighten until the barometer tube is installed.

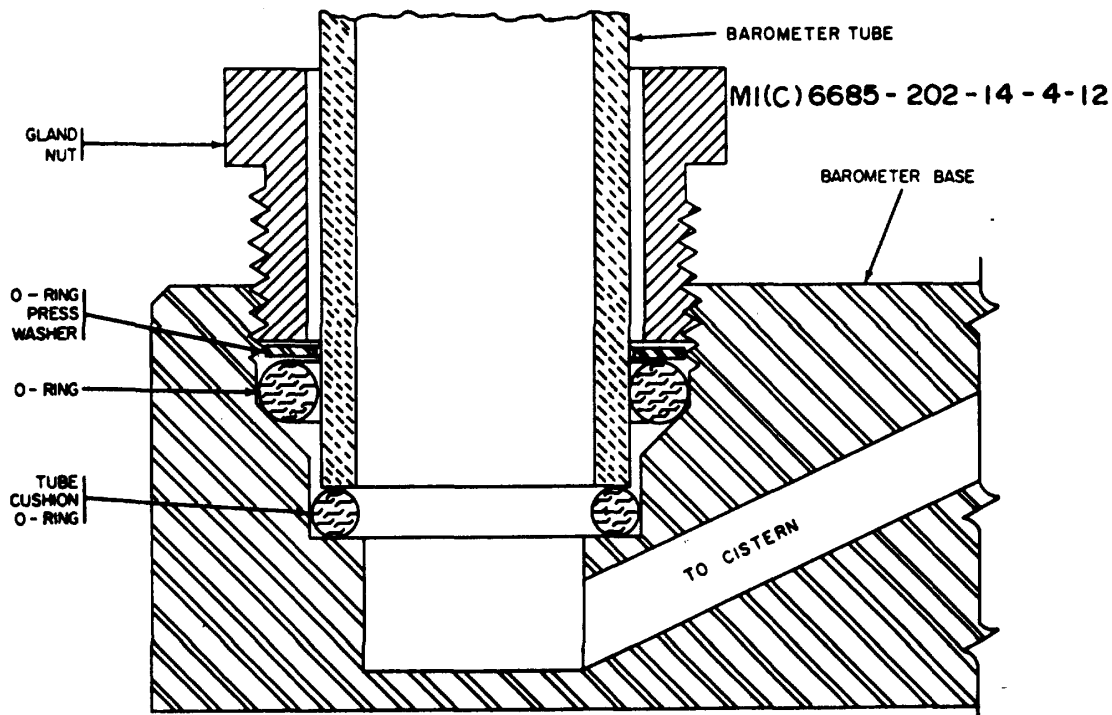

Figure 4-12. Installation of gland nut.

c. Thermometer and Scale Rod Assemblies. If the thermometer has been removed for replacement, imbed the replacement thermometer in the existing clay block inserts and install the holder and screws.

**NOTE**

**Older barometers use the thermometer rod as a current path to the light bracket; therefore, the rod must be insulated from ground with insulator washers. Use the insulator washers recovered during disassembly.**

d. Constant Vacuum Regulator Adjustment. Adjust control spring in housing by turning crank wheel

clockwise until upper and lower housings barely meet. Hold upper housing and crank wheel and then unscrew lower housing by turning it counterclockwise (looking at the bottom of lower housing) until sections are separated. Tighten split locknut and machine screw. Reassemble upper and lower housing. Check for proper adjustment of valve seat by raising valve disk approximately 1/16 inch off seat retainer and observing that seat retainer rests on spacers.

**4-15. Calibration**

The barometer shall be calibrated at the intervals prescribed by TB 750-236. The procedure for performing the calibration shall be in accordance with TB 9-6685-32050.

## CHAPTER 5

**SHIPMENT, STORAGE, AND DESTRUCTION OF MATERIEL TO PREVENT ENEMY USE**

## 5-1. Shipment and Limited Storage

*a. Responsibility.* When shipping the barometer, the officer in charge of preparing the shipment will be responsible for furnishing the materiel in a serviceable condition and properly processed for shipment, including the preparation of Army shipping documents.

*b. Army Shipping Documents.* Prepare all Army shipping documents in accordance with TM 38-750.

*c. Preparation for Shipment.* Materiel removed from storage for shipment need not be reprocessed unless inspection reveals it to be inadequately preserved or when it is necessary because of anticipated in-transit weather or shipping conditions. Preservatives must not be removed or disturbed unless necessary to insure that the materiel is complete and serviceable. If preservatives are removed, they must be restored prior to shipment.

*d. Preparation for Limited Storage.* To prepare the barometer for limited storage, wipe the scale and thermometer rods, and the edges of the scale and cam bar with a soft cloth to which a few drops of instrument oil, specification MIL-L-6085, have been applied. If physical damage is not likely to occur during storage, the barometer can be stored in its normal position with the mercury retained in the cistern. Use the procedure for preparing the barometer for shipment, paragraph 5-1e below, omitting removal of the mounting platform, step (7). Protect the barometer from dust and dirt by covering it with the plastic dust cover provided. If damage is likely to occur during storage, carry out provisions of paragraph 5-1e completely and package it in its inner container in accordance with paragraph 5-1f.

*e. Preparation for Shipment.* Dismantle the barometer for shipment in the following manner:

(1) Release the vacuum in the barometer tube.

(2) Tilt the barometer over backwards to get all the mercury in the cistern. Support the top of the barometer to maintain this position.

(3) Remove the cistern nipple (or micrometer) and securely close the mercury locking

screw in the bottom of the cistern (fig. 3-1). Use a clean screwdriver, inserted through the cistern lid.

**CAUTION**

**Do not overtighten the mercury locking screw. Overtightening can damage the valve seat.**

(4) Replace the cistern nipple (or micrometer) with the cistern shipping plug, together with its gasket.

(5) On the type A-1, close the tube seal valve and cover the end of the tube evacuation nipple with the top of a medicine dropper or similar cover.

(6) On the modified barometer, remove the evacuation manifold and cover the end of the tube evacuation port with a 3/8-inch tubing cap or suitable fitting.

(7) Remove the barometer from the mounting platform by releasing the two socket head screws.

(8) Remove the batteries.

(9) Wrap the magnifier and micrometer and place them, the cistern nipple, and the squeeze pump in the shipping case.

*f. Interior Packaging.* For interior packaging, a wooden box 6 inches high, 8 inches wide, and 45 inches long, is used. The box is constructed with 3/4-inch Group 1 wood sides and ends, and 5/16-inch plywood bottom and top. The barometer is supported inside the box by a two-piece yoke, one inch thick, with a semicircle cut in each half. The yoke is positioned approximately eight inches from one end of the box. The other end of the box is drilled to receive the two socket head screws which fasten the barometer to its mounting platform. With the mounting platform removed, these screws are used to secure the base to the end of the box. After preparing the barometer, package it as follows: (1) The barometer, mounting platform, and micrometer shall be individually wrapped in waxed paper conforming to MIL-B121, Type II, Grade A, Class 1.

(2) Place desiccant, in accordance with MIL-D-3464, next to the wrapped barometer and mounting platform.

(3) Place the barometer, mounting platform and micrometer in moisture proof bags.

(4) Evacuate air from the bags and heat seal the openings.

(5) With only the lower half of the yoke in place, position the barometer in the box.

(6) Attach the base to the end of box with the two mounting screws. Use rubber washers where the screws penetrate the moisture proof bag.

(7) Place the upper half of the yoke over the wrapped barometer and nail in place.

(8) Attach the top of the box.

*g. Exterior Packing.* A cleated plywood box is used as an outer container. The box should be approximately 22 inches high, 24 inches wide, and 70 inches long. A waterproof liner should be provided inside the container. The interior box is centrally packed within the outer container as follows:

(1) A minimum of eight inches of creped-cellulose wadding shall be placed on all sides and ends, between the boxed barometer and the exterior container. A 16- by 16-inch plywood square is attached to either end of the inner box to distribute the load on the cellulose wadding.

(2) Creped-cellulose wadding at least four inches thick shall surround the mounting platform.

(3) Secure the top of the container and mark for shipment. The marking shall indicate, "Barometer Metric Mercurial, Altitude Test, Type A-1 or Barometer, Metric Mercurial, Modified"; and "Delicate Instrument, Handle with Care."

## **5-2. Destruction of Materiel to Prevent Enemy Use**

This section covers methods of destroying materiel, when in danger of imminent capture, in order to prevent enemy use.

*a. General.* In the event that the barometer can not be removed in time to avoid imminent capture by enemy forces, it should be destroyed to prevent enemy use.

*b. Destruction by Mechanical Means.* The barometer is a delicate instrument and can readily be rendered unserviceable by smashing the precision bore barometer tube and mercury cistern. Remove or bend and twist the vernier scales, scale bar, or vernier slide. Twisting these items out of shape will make it impossible to obtain accurate readings. Scatter the mercury, and burn instruction books. A number of blows with a hammer or other instrument will render it useless to any enemy. Scatter or bury spare parts and similarly destroy any associated equipment.

## APPENDIX A

## REFERENCES

**A-1. Publication Indexes**

The following publication indexes should be consulted frequently for latest changes or revisions of references given in the appendix and for new publications relating to material covered in this manual.

## Military Publications:

Index of Administrative Publications..... DA Pam 310-1

Index of Blank Forms..... DA Pam 310-2

Index of Doctrinal Training and Organizational Publications ..... DA Pam 310-3

Index of Technical Manuals, Technical Bulletins, Supply Manuals (Types 7, 8, and 9), Supply Bulletins, Lubrication Orders, and Modification Work Orders ..... DA Pam 310-4

**A-2. Direct Support and General Support Maintenance**

Repair Parts and Special Tools List for Calibration Standards Sets Procedure for Requisitioning Parts for Calibration Equipment ..... TM 9-4931-700-34P-1

**A-3. Forms**

The following forms pertain to this materiel:

DA Form 9-1, Materiel Inspection Tag

DA Form 9-79, Parts Requisition

DA Form 829, Rejection Memorandum

DA Form 1296, Stock Accounting Record

DA Form 1297, Title Insert (Formal Accountability)

DA Form 1546, Request for Issue or Turn-in

DA Form 2028, Recommended Changes Publications

DA Form 2402, Exchange Tag

DA Form 2404, Equipment Inspection and Maintenance Work Sheet

DA Form 2405, Maintenance Request Register

DA Form 2407, Maintenance Request

DA Form 2507, Shipment Receipt/Lift Notice

DD Form 6, Report of Damaged or Improper Shipment

DD Form 250, Materiel Inspection and Receiving Report

**A-4. Other Publications***a. General*

Accident Reporting and Records .....AR 385-40

Authorized Abbreviations and Brevity Codes..AR 310-50

Calibration Procedure for Modified Metric Mercurial Barometer(7913093) and Metric Mercurial Barometer

(7907105) ..... TB9-6685-320-50

Dictionary of United States Army Terms.....AR 310-25

Shop Mathematics ..... TM 9-2820

The Army Equipment Record System and Procedures ..... TM 38-750

*b. Maintenance*

Cleaning of Ordnance Materiel..... TM 9-208-1

Command Maintenance Management Inspections

.....AR 750-8

Finishing of Metal and Wood Surfaces..... MIL-STD-171

General Specification for Soldering Process. MIL-S-6872

Lubricating Oil, Instrument, Aircraft, Low Volatility

..... MIL-L-6985A

Lubrication of Ordnance Materiel ..... TM 9-273

USA Metrology & Calibration System .....AR 750-25

Materials Used for Cleaning, Preserving, Abrading and

Cementing Ordnance Materiel; and Related Materials

Including Chemicals ..... TM 9-247

Organization, Policies, and Responsibilities for

Maintenance Operation .....AR 750-5

Use and Care of Hand Tools and Measuring Tools

..... TM 9-243

*c. Shipment and Storage*

Barrier Materiel, Greaseproofed, Waterproofed, Flexible

..... MIL-B-121

Desiccants Activated, Bagged. Packing Use and Static

Dehumidification .....MIL-D-344B

Parts, Equipment and Tools for Ordnance Materiel,  
Packaging of ..... MIL-P-14232  
Preservation, Packaging and Marking .....AR 700-15  
Report of Damage or Improper Shipment.....AR 700-5

Requisitioning, Receipt and Issue System ....AR 7325-10  
Storage and Materials Handling ..... TM 743-200-1



## APPENDIX B

## MAINTENANCE ALLOCATION CHART

**B-1. General**

This appendix contains the Maintenance Allocation Chart (MAC) which lists the lowest echelon authorized to perform each maintenance operation, the tools required, and remarks regarding the maintenance of the item.

**B-2. Explanation of Columns**

*a. Column 1, Reference Numbers.* Column 1 lists reference numbers, the purpose of which is to identify groups, components, assemblies, and subassemblies with the next higher assembly. Reference numbers are assigned in sequence to group, components, or assemblies listed in Column 2. These begin with reference number 1 for the first group, component or assembly; 2 for second and so on. Parts of assembly are numbered in sequence using a decimal following the number of the assembly. For example, the third maintainable part of an assembly numbered 8 would be numbered 8.3.

*b. Column 2, Component and Related Operations.* Column 2 lists the end item on which maintenance can be performed, and lists the maintenance operations which are authorized to be performed on it.

*c. Columns 3, 4, 5, and 6.* Indicate by "X" the lowest maintenance level authorized to perform the prescribed maintenance operation.

*d. Column 7, Tools Required.* Lists special tools or tool sets and test equipment required to perform the prescribed maintenance operation.

*e. Column 8. Remarks.* Used as a cross reference for a particular maintenance function or any special explanatory notes.

**B-3. Use of Chart**

Determine from the chart the echelon that is authorized to perform the required operation. Maintenance operations are defined below:

**Service:** To clean, preserve, and replenish lubricants.

**Adjust:** To regulate periodically to prevent malfunction.

**Inspect:** To verify serviceability and to detect incipient electrical or mechanical failure by scrutiny.

**Test:** To verify serviceability and detect incipient electrical or mechanical failure by use of special equipment such as gages, meters, etc.

**Replace:** To substitute serviceable assemblies, subassemblies and parts of unserviceable component parts.

**Repair:** To restore an item to serviceable condition through correction of a specific condition. This function includes, but is not limited to, inspecting, cleaning, preserving, adjusting, replacing, welding, riveting, and straightening.

**Overhaul:** To restore an item to a completely serviceable condition as prescribed by maintenance serviceability standards.

**NOTE**

**Symbol "X"** The Symbol "X" placed in the appropriate column indicates the echelon responsible for performing that particular maintenance operation, but does not necessarily indicate that repair parts will be stocked at that level. Echelons higher than the echelon marked "X" are authorized to perform the indicated operations.

**MAINTENANCE ALLOCATION CHART  
FOR  
END ITEM: BAROMETER, HASS TYPE A-1 OR TYPE  
A-1 MODIFIED**

GROUP NUMBER (1)	COMPONENT AND RELATED OPERATIONS (2)	ORG'N MAINT.		DIR SUP.	GEN SUP.	TOOLS REQ'D (7)	REMARKS (8)
		O/C (3)	O (4)	DS (5)	GS (6)		
1	Barometer, Hass Type A-1 or Type A-1 Modified Service Inspect Replace Repair Adjust Overhaul	X X				X X X X	No special tools are required at any level of maintenance.

**APPENDIX C**  
**BASIC ISSUE ITEMS LIST, REPAIR PARTS LIST,**  
**AND ITEMS TROOP INSTALLED OR AUTHORIZED LIST**  
**Effective Date: 1 July 1973**

**Section I. INTRODUCTION**

**C-1. General**

This appendix is a list of basic issue items. It is composed of those items which make up the major end items of equipment and the supplies, assemblies, and repair parts that are issued with the equipment and are required for stockage.

**C-2. Explanation of Columns**

*a. Source, Maintenance, and Recoverability Code (SMR) (Col 1).*

(1) *Source Code.* This column indicates the source for the listed items. The source code used in this list is:

Code	Explanation
P	Repair parts, special tools and test equipment supplied from the GSA/ DSA or Army supply system and authorized for use at indicated maintenance categories.

(2) *Maintenance Code.* This column indicates the lowest category of maintenance authorized to install the listed item.

Maintenance codes used in this list are:

Code	Explanation
O	Organizational maintenance
F	Direct support maintenance
H	General support maintenance

(3) *Recoverability Code.* This column indicates whether unserviceable items should be returned for recovery or salvage. When no code is indicated, the item is expendable and not recoverable. Recoverability codes used in this list are:

Code	Explanation
R	Items which are economically repairable at direct and general support maintenance levels are normally furnished by supply on an exchange basis.
T	High dollar value recoverable items which are subject to special handling and are issued on an exchange basis. Such items are normally repaired or overhauled at Depot maintenance activities.

*b. Federal Stock Number (Column 2).* This column indicates the Federal stock number assigned to the item and will be used for requisitioning purposes.

*c. Description (Column 3).* This column indicates the Federal item name and a minimum description required to identify the item. The last line indicates the reference number followed by the applicable Federal Supply Code for Manufacturer (FSCM) in parenthesis. The FSCM is used to designate the manufacturer, distributor, or Government agency and is identified in SB 708-42.

*d. Unit of Measure (Column 4).* This column indicates the standard or basic quantity by which the listed item is used in performing the actual maintenance function. This measure is expressed by two character alphabetical abbreviation, e.g., ea, in., pr, bk, etc., and is the basis used to indicate quantities and allowances in quantity columns.

*e. Quantity Furnished with Equipment (Column 5).* This column indicates the quantity of the item furnished with the equipment.

*f. Illustration (Column 6).* This column indicates the figure number of the illustration that depicts the listed item. When more than one item appears on an illustration, the item number is also indicated.

Section II. BASIC ISSUE ITEMS LIST

SMR Code	Federal Stock Number	Description	Unit of Meas.	Qty furn with equip unit	Illustration	
					Fig No.	Item No.
PHT	6685-537-9171	<p>MAJOR ITEM (type A-1) The following item is to be requisitioned for initial use only.</p> <p>BAROMETER, MERCURIAL: 0 to 790 mm range</p> <p>COMPONENTS OF MAJOR COMBINATION (type A-1) The items listed below are issued as components of the major combination for initial issue. Replacement items will be requisitioned separately under their individual stock numbers. Applicable spare parts and tools and equipment, as listed under separate headings below, are issued with each major combination in addition to the components listed below.</p>	ea	1	1-1	
PHT	4310-203-3057	VACUUM PUMP, ROTARY, POWER DRIVEN: 1/3 hp, 115 vac, 60 Hz (840133-00)	ea	2	4-9	
PHT	6685-306-5604	<p>REGULATOR, CONSTANT VACUUM: 0 to 60 in. Hg. (841002-00)</p> <p>Tools and equipment for: Barometer, mercurial, type A-1 NONE</p> <p>MISCELLANEOUS MATERIAL (type A-i)</p> <p>The items listed under subheadings below are not issued with the major item, but are requisitioned and issued in accordance with tables of organization and equipment, tables of allowances, or as otherwise authorized.</p>	ea	2	4-11	
PF	4730-277-6859	ADAPTER, STRAIGHT, PIPE TO HOSE: br, hex wrenching surface between ends, pipe end 1/8-27NPT, hose end 1/4 in. id (825877-00).	ea	5		
PF	4730-187-0087	ADAPTER, STRAIGHT, PIPE TO TUBE: al, 1-3/8 in. lg, 1/4 in. od tube to 1/8 in. pipe (850191-00)	ea	1		
PF	4730-278-4348	ADAPTER, STRAIGHT, PIPE TO TUBE: br, 1-1/16 in. lg o/a in. od, both ends male, 7/16 and 3/8-18NPT (840150-00).	ea	2		
PF	4730-194-1120	ADAPTER, STRAIGHT, PIPE TO TUBE: cop., 1-7/64 in. lg, 1/4 in. tube od to 1/8 in. pipe (801298-00).	ea	3		
PF	4730-287-0545	ADAPTER, STRAIGHT, PIPE TO TUBE: cop., 1-3/16 in. lg, 3/8 in. od tube to 1/8 in. pipe (890376-00).	ea	1		

## Section II. BASIC ISSUE ITEMS LIST - Continued

SMR Code	Federal Stock Number	Description	Unit of Meas.	Qty furn with equip unit	Illustration	
					Fig No.	Item No.
PO	6135-120-1020	BATTERY, DRY; standard flash light type, signal corps designation BA-30 type C (to be requisitioned through normal supply channels; not issued with equipment).	ea	2		
PFR	6640-403-3000	BEAKER, LABORATORY: pyrex glass, 200 milliliters cap., (840186-00).	ea	1		
PFR	6640-510-4521	BLOWER, HAND, LABORATORY: 2 soft ru bulbs, 50 milliliters cap, first bulb w/check valve to retain pressure, second bulb acts as air reservoir, supplied w/24 in. tube (840216-00).	ea	2		
PFR	7610-233-9597	BOOK: Handbook of Chemistry and Physics (808180-00).	ea	1		
PF	4730-277-9386	BUSHING, PIPE cop. 1/4-18 NPT male end, 1/8-27NPT female end, 25/32 in. lg, o/a (809247-00)	ea	2		
PFR	6160-834-8058	CASE, WOODEN CARRYING: (for Barometer; approx size 14"H x 15" W x 48"L).	ea	2		
PF	6640-418-0800	CLAMP, RUBBER TUBING, REGULATING: screw type, accommodates up to 1/2 in. od. tubing, w/swivel jaw (840508-00)	ea	1		
PF	4730-256-4209	CROSS PIPE: cop., female 1/8-27NPT, 37/64 in. lg ea leg, all ends identical (853301-00).	ea	1		
PF	4730-278-9352	ELBOW, PIPE: br, cd-pltd, 90 deg, both ends identical, 1/8-27NPT, 41/64 in. lg ea leg, (851704-00)	ea	1		
PFR	4330-274-8731	FILTER, FLUID, PRESSURE: permanent type, 150 psi max rated pressure, one element, reusable, w/o cleaning blade, 3-3/4 in. dia, 7-3/4 in. lg w/drain cock and glass bowl (840218-00).	ea	1		
PFR	6640-426-7100	FUNNEL, COMMON LABORATORY: glass, 16 oz cap, (840801-00)	ea	1		
PF	4720-811-4824	HOSE ASSEMBLY, RUBBER: 800 psi burst pressure, 1/4 in. id, 1/2 in. od, 96 in. lg, al fittings ea end, 7/16-20UNF-3B (851721-00)	-			
PF	4720-542-2275	HOSE ASSEMBLY, RUBBER: 800 psi burst pressure, 1/4 in. id, 1/2 in. od, 12 in. lg, al fittings ea end, 7/16-20UNF-3B (890414-00)				

## Section II. BASIC ISSUE ITEMS LIST - Continued

SMR Code	Federal Stock Number	Description	Unit of Meas.	Qty furn with equip unit	Illustration	
					Fig No.	Item No.
PF	4720-289-2976	HOSE ASSEMBLY, RUBBER: 1250 psi burst pressure, 1/4 in. id, 1/2 in. od, 24 in. lg, al fittings ea end 7/16-20 UNF-3B (851155-00)	ea	1		
PF	5970-224-5276	INSULATING COMPOUND, ELECTRICAL: paste form, 8 oz tube (801362-00)	ea	2		
PF	5120-607-5980	KEY, SOCKET HEAD SCREW: corr-res-S, screwdriver type, 1-1/8 in. lg x 3/16 in. dia of hid, 1-7/8 in. lg O/A, 0.087 dia of bid (832128-00)	ea	1		
PO	6240-155-7864	LAMP, 3v, 0.19 (GE No. 323)	ea	1		
PO	9150-273-8663	LUBRICATING OIL, VACUUM PUMP: light grade low vapor pressure, 1 qt bottle (801369-00).	ea	1		
PFR	6640-255-8271	MANUAL, technical, TM 9-6685-202-14	ea	1		
PFR	6810-264-6738	MAGNIFIER: monocular type, 1 lens, 3 in. dia, mtl frame, w/removable plastic hdl (840950-00)	ea	1		
PFR	6810-264-6738	MERCURY, REAGENT: 0.00001 pet max impurities, triple distilled, 6 lb plastic bottle w/dispenser tip (831364-00)	ea	3		
PFR	6515-349-3400	NEEDLE, HYPODERMIC: corr-res-S, 1-1/2 in. cannula, lucrlock bub, regular bevel pt (816890-00)	ea	2		
PF	4730-186-7785	NIPPLE, PIPE: al, anodized, 3/8-18NPT x 1-1/2 in. lg (802342-00)	ea	4		
PF	4730-186-7797	NIPPLE, PIPE: br, cd-pltd, 1/8-27NPT x 31/32 in. lg (801486-00)	ea	1		
PF	4730-289-1072	NIPPLE, PIPE: br, cd-pltd, 3/8-18NPT x 1-15/32 in. lg (852086-00)	ea	2		
PF	4730-289-1072	NIPPLE, PIPE: br, cd-pltd, 3/8-18NPT x 1-15/32 in. lg (852086-00)	ea	2		
PFR	6830-264-9086	NITROGEN, TECHNICAL: 99.5 pct min purity by volume of gas (dry) cylinder, 120 cu ft rated cap., grade A, type 1 (830689-00)	ea	1		
PF	6640-597-6745	PAPER, LENS: 4 in. W, 6 in. ig (840528-00)	ea	2		
PFR	5120-640-6356	PLIERS, RETAINING RING: for internal type rings, w/o bracket or spring, accommodates ring sized 25 to 31, 37 thru 102, and 75 thru 137 range (831869-00)	ea	1		
PFR	6685-511-4476	PSYCHROMETER: wet and dry bulb, 30 deg to 110 deg F range, +1 deg F accuracy, fan driven by four 1-1/2 v flashlight cells, 6-1/8 in. lg, 4-1/4 in.W, 5 in. H (806302-00)	ea	1		

## Section II. BASIC ISSUE ITEMS LIST - Continued

SMR Code	Federal Stock Number	Description	Unit of Meas.	Qty furn with equip unit	Illustration	
					Fig No.	Item No.
PFR	6680-626-0015	REGULATOR, PRESSURE, COMPRESSED GAS: br, for nitrogen gas, cyl gage, 2-1/2 in. dia, 3000 psi range, delivery gage 2-1/2 in. dia, 0 to 60 psi range, 40 psi max working pressure w/automatic relief valve (828584-00)	ea	1		
PF	4730-302-1499	RUBBER TUBING CONNECTOR: br, 1-5/8 in. lg, for connecting ru tubing 7/16 in. thru 1/4 in. id (840818-00)	ea	1		
PFR	6515-380-4300	SYRINGE, LUER: Yale B-D Lok, bbl type 20 cc cap, sgle scale, lcc gard, glass, slip type w/plunger clasp and button type thumb ring (816591-00)	ea	2		
PFR	1190-540-1413	TANK, PRESSURE: al, enameled inside and outside, 5-3/4 in. lg, 3-1/2 in. dia w/ enclosed baffle (116267-00)	ea	1		
PF	4730-278-3989	TEE, PIPE: cop., cd-pltd, all ends identical, 1/8-27NPT female (851026-00)	ea	2		
PF	4730-263-2732	TEE, PIPE: 2 female fittings, 1/8-27NPT, 33/64 in. lg one leg 5/8 in. lg, 1/8-27NPT male thread (831956-00)	ea	2		
PF	4730-202-9177	TEE, HOSE, al, 1-3/8 in. lg ea leg, serrated ends for 3/16 to 5/16 in. id hose (840806-00)	ea	3		
PF	4720-541-0514	TUBE, RUBBER, 3/16 in. id, 10 ft lg, (182D4-2) with glass probe or	ea	1		
PF	9330-017-5373	TUBE, TYGON: R-3603F	ft	1		
PF	4730-348-6003	TUBE, RUBBER: 5/16 in. wall thk, 7/16 in. id 10 ft lg, (840707-00)	ea	1		
PFR	4820-726-9309	VALVE, ANGLE: 0.062 in. valve size 0.093 orifice size 1000 to 10,000 psi range, identical ends, female 1/8-27NPT, 4-3/4 in. o/a lg, manually operated (836040-00)	ea	1		
PFR	4820-274-3653	VALVE, PRESSURE REGULATING: 150 psi rated air inlet working pressure at no rated temp, 5 to 125 psi reduced outlet pressure, female end connections 3/8-18 NPT, (841150-00)	ea	1		
PHT	6680-182-7792	MAJOR ITEM (type A-1 Modified) The following item is to be requisitioned for initial use only. BAROMETER, MERCURIAL, METRIC (MODIFIED): 0 to 790 mm Hg. range (7913093)	ea	2	1-1	

Section II. BASIC ISSUE ITEMS LIST - Continued

SMR Code	Federal Stock Number	Description	Unit of Meas.	Qty furn with equip unit	Illustration	
					Fig No.	Item No.
PHT PHT	4931-929-8403 6685-306-5604	COMPONENTS OF MAJOR COMBINATION (type A-1 modified) The items listed below are issued as components of major combination for initial issue. Replacement items will be requisitioned separately under their individual stock numbers. Applicable spare parts and tools and equipment, as listed under separate headings below, are issued with each major combination in addition to the components listed below. PUMP, VACUUM (7912361) REGULATOR, CONSTANT VACUUM: 0 to 60 in. mercury (FA 149) Tools and equipment for barometer, mercurial, metric, (modified) NONE Miscellaneous material (type A-1 Modified) The items listed under subheadings below are not issued with the major item but are requisitioned and issued in accordance with tables of organization and equipment, tables of allowances, or as otherwise authorized.	ea ea	2 1	4-10 4-11	
PF	7913322	ACCESSORY KIT	ea	1		
PF	4931-134-4742	ADAPTER, STRAIGHT, PIPE TO HOSE: 1/8 in. male NPT to 1/2 in. serrated tube (2-MHC-4S)	ea	5		
PF		ADAPTER, AMINCO-TYPE TO PIPE: ss, both ends female, pipe end 1/8-27NPT, tube end w/gland nut and sleeve for 1/4 in. od tube (45-16007)	ea	2		
PF		ADAPTER, AMINCO-TYPE: ss, both ends male, pipe end 7/16-20NF, 37° flare for 1/4 in. od tube, tube end for 1/4 in. od tube (3460-34-23)	ea	2		
PF		ADAPTER, AMINCO-TYPE TO PIPE: ss, both ends female, pipe end 1/4-18 NPT, tube end w/gland nut and sleeve for 1/4 in. od tube (45-16071)	ea	1		
PF		ADAPTER, AMINCO-TYPE TO PIPE: ss, male to female, male end 1/8-NPT, female end with gland nut and sleeve for 1/4 in. od tube (45-16307)	ea	2		
PF		ADAPTER, AMINCO-TYPE TO PIPE: ss male to female, male end 1/4-18 NPT, female end w/gland nut and sleeve for 1/4 in. od tube (45-16370)	ea	1		



Section II. BASIC ISSUE ITEMS LIST - Continued

SMR Code	Federal Stock Number	Description	Unit of Meas.	Qty furn with equip unit	Illustration	
					Fig No.	Item No.
PF		ADAPTER, AMINCO-TYPE TO MALE THD: ss, male to female, male end 7/16 od 2UNF, 37° flare angle, female end w/gland nut and sleeve for 1/4 in. od tubing (45-18052).	ea	2		
PF		ADAPTER, AMINCO-TYPE: ss male to male, 1/4 in. od tube (3460-34-21)	ea	1		
PF		ADAPTER, AMINCO-TYPE: ss, female to female, gland nuts and sleeves for 1/4 in. od tube (45-12306)	ea	1		
PF		ADAPTER, AMINCO-TYPE: ss male to male, 1/4 in. od tube and 1/8-27NPT (3460-34-1).	ea	1		
PF		ADAPTER, AMINCO-TYPE: ss male to male, 1/4 in. od tube and 1/4-18NPT (3460-34-3)	ea	1		
PF		ADAPTER, AMINCO-TYPE: ss male to female, male end for 1/4 in. od tube, female end for 1/8-27NPT (3460-34-11)	ea	1		
PF		ADAPTER, AMINCO-TYPE: ss male to female, male end for 1/4 in. od tube, female end for 1/4-18NPT (3460-34-13)	ea	1		
PF	8120-264-5529	ADAPTER, REGULATOR (812) ASSEMBLY TUBE (7913090)	ea	1		
PO	6135-120-1020	BATTERY, DRY standard flash light type, type C BA-30	ea	2		
PFR	6640-403-3000	BEAKER, LABORATORY, pyrex glass, 200 milliliters cap (NNN-B-175)	ea	1		
PFR	7610-233-9597	BOOK, Handbook of Chemistry and Physics (808180-00)	ea	1		
PF		BUSHING, PIPE (8486940)	ea	5		
PF		BUSHING, REDUCING: ss, male end 1/2-14-NPT, female end 1/8-27 NPT (8-RB-2-316)	ea	2		
PF	4730-302-1499	CONNECTOR, RUBBER TUBING: (18302)	ea	1		
PF		CONNECTOR: male (8135899)	ea	6		
PF		CONNECTOR: male, ss, one end 1/8-27NPT, other end 9/16-18NF, 37° flare angle (6-2FBTX-SS)	ea	2		
PF		CROSS PIPE: sS, 1/8-27 NPT parts (1/8 KMMOO-SS 2-CS-316)	ea	1		
PF		DIAPHRAGM (7913099)	ea	1		
PF		ELBOW: Swivel nut, 90° (8986877)	ea	1		

Section II. BASIC ISSUE ITEMS LIST - Continued

SMR Code	Federal Stock Number	Description	Unit of Meas.	Qty furn with equip unit	Illustration	
					Fig No.	Item No.
PF		ELBOW: 900 male, ss, one end male, 7/16-20NF, 370 flare angle, other end 1/8-27NPT (4-CBTX-SS).	ea	1		
PF		ELBOW, PIPE: ss, 900 both parts female 1/8-27NPT (1/8-D-D-SS 2-E-316)	ea	1		
PF	6640-426-7100	FITTING, HOSE: (1/4-4-30682-4)	ea	2		
PFR		FUNNEL, COMMON LABORATORY: glass, 16 ounce cap	ea	1		
PFR		GAGE, Vacuum (7913098)	ea	1		
PF		HOSE, FLEXIBLE, swivel ends female, 7/16-20NF, 370 flare angle (3/16-4-4-300-606-1)	ea	1		
PF	6650-880-7615	INSULATING, COMPOUND, ELECTRICAL: paste from 8 oz tube.	ea	2		
PFR	6650-514-3531	MAGNIFIER: monocular type (CC-M-95)	ea	1		
PF	6515-349-3400	NEEDLE: Hypodermic(GG-N-196)	ea	1		
PF		NIPPLE: AMINCO-TYPE, ss, 1/4 in. od, 3/32 in. id, 3-1/2 in. lg, male, w/590 conical seats w/threaded ends (45-11064)	ea	2		
PF		NIPPLE: AMINCO-TYPE, ss, 1/4-in. id, 3/32 in. id, 2-1/2 in. lg, male w/59° conical seats w/threaded ends (45-11062)	ea	2		
PF	4730-770-1570	NIPPLE, PIPE: Hex, ss, both ends male 3/8-27NPT (3/8FF-SS 6-HN-316)	ea	4		
PF	4730-043-3089	NIPPLE, PIPE: Hex, ss, both ends male 1/8-27NPT (1/8 FF-SS 2-HN-316).	ea	4		
PF		NIPPLE, TUBE: (8486543)	ea	2		
PF	6640-597-6745	PAPER, LENS: (NNN-P-40)	bk	1		
PFR	5120-640-6356	PLIERS, RETAINING RING (GGG-P-00480)	ea	2		
PFR	4931-400-7107	PRESSURE ACCESSORIES: for pressure accessory kit (7913289)	ea	1		
PF		PLUG: AMINCO-TYPE, ss (45-11320)	ea	2		
PFR	6680-626-0015	REGULATOR, PRESSURE compressed gas (4424)	ea	1		
PF		SEAL: conical, cop for 37° flared 1/4-in. tube pressure fittings (VSF-1015C4B)	ea	100		
PF		SEALANT: pipe thread (ribbon teflon) 1/2 in. wide (MIL-T-27730)	ea	2		
PFR	6515-380-4300	SYRINGE LUER: 20cc cap, type 1, size 4	ea	2		
PF		TEE BRANCH: ss, both ends female 1/8-27NPT, center male 1/8-27NPT (2-BT-316)	ea	2		
PF		TEE PIPE: ss, all parts female 1/8-27NPT (1/8 MMO-SS 2-T-316)	ea	1		

## Section II. BASIC ISSUE ITEMS LIST-Continued

SMR Code	Federal Stock Number	Description	Unit of Meas.	Qty furn with equip	Illustration	
					Fig No.	Item No.
PF	4720-541-0514	TUBE, VACUUM GAGE (7913092)	ea	1		
PF		TUBING: rubber (3/16 in., 10 ft lg) (18204-2)	ea	1		
PF	4720-348-6003	TUBING: rubber (7/16 in, 10 ft lg) (18204-6).	ea	2		
PF	9330-071-5373	TUBING: tygon, R3603, 1/4 in. id, 1/2 in., od, 50 ft lg	ea	1		
PF	4820-721-9309 VALVE,	VALVE, ANGLE (53-3-12)	ea	2		
PF		ANGLE, NEEDLE: ss operating pressure, 10,000 psi, inlet port 90° to outlet port, inlet male 1/8-27NPT, outlet female 1/8-27NPT (2014).	ea	1		

**Section III A.**  
**REPAIR PARTS LIST, BAROMETER, MERCURIAL,**  
**TYPE A-1 AND BAROMETER, METRIC MERCURIAL,**  
**TYPE A-1 MODIFIED**

Manufacturer's Part Number	Nomenclature	Figure and Index Number
MS-35207-261	Screw, machine	4-3-2
MS-25281-F6	Clamp, loop, plastic	-3
7913085	Union, reducing	-4
1 HIC 10-00-13	Sleeve, top cap	-5
HIC 6-32 x 1/4	Screw, cap, socket head	-6
HIC 3/16 OD. 1/16 ID x 1/4 lg	Tubing, plastic	-7
HIC 10-00-11-a	Nipple, tube evacuating	-8
HIC 10-00-14-C	Disc, top mounting	-9
HIC 10-00-15-C	Tube, barometer	-10
HIC 10-32 x 3/4	Screw, cap, socket head	-11
HIC 10-30-16-B	Block	-12
HIC 4-40 x 1/8	Setscrew	-13
HIC 4-40 x 1/2	Screw, cap, socket head	-14
HIC No. 4	Washer, flat	-15
HIC 1/8 in. dia.	Clamp, cable	-16
HIC 4-40 x 3/8	Screw, cap, socket head	-17
HIC 12-A-1055	Jack, tip, light source	-18
HIC 10-41-03-A	Holder, thermometer	-20
HIC 4-40 x 3/8	Screw, cap, socket head	-21
HIC 10-41-01-A	Thermometer	-22
HIC 10-30-01-C	Bar, cam	-24

<sup>1</sup> See footnote at end of table.

**Section III A.**  
**REPAIR PARTS LIST, BAROMETER, MERCURIAL,**  
**TYPE A-1 AND BAROMETER, METRIC MERCURIAL,**  
**TYPE A-1 MODIFIED-Continued**

Manufacturer's Part Number	Nomenclature	Figure and Index Number
<sup>1</sup> HIC 10-30-02-B	Stud, cam bar	-25
HIC 4-40 x 3/4	Screw, cap, socket head	-26
HIC No. 4	Washer, flat	-27
HIC 10-30-30	Washer, flat	-28
7913097-1	Scale (HIC 10-30-19-B)	-29
HIC 4-40 x 3/8	Screw, cap socket head	-30
HIC No. 4	Washer, flat	-31
HIC 10-30-09-A	Rod, adjusting	-32
HIC 10-30-08-B	Bracket, adjusting	-33
HIC 10-30-07-A	Nut, adjusting	-34
HIC 10-30-29	Washer, spring	-35
HIC 4-40 x 3/8	Screw, cap, socket head	-36
7913326	Micrometer	-37
7913096	Mount, block, gage	-38
MS-16995-30	Screw, cap, socket head	-39
HIC 10-50-00-A	Platform assembly	-41
HIC 5/16-24 x 1/2	Screw, cap, socket head	-42
HIC 10-40-01-A	Rod, thermometer	-43
HIC 10-30-17-B	Rod, scale	-44
HIC 1/4-28 x 1 1/4	Screw, cap, socket head	-45
HIC 5/16-24 x 1	Screw, cap, socket head	-46
7913095	Trap, glass	-47
HIC 4-40 x 3/4	Screw, cap, socket head	4-4-A
HIC 10-20-16	Nut, locking	-B
HIC No. 4	Washer, steel	-C
HIC 10-00-08-A	Washer, valve	-D
HIC 10-00-09-A	Diaphragm	-E
HIC 10-00-06	Stud, valve	-F
HIC 4-40	Nut, stainless steel	-G
HIC 10-00-07	Valve, ball	-H
HIC 4-40 by 3/8	Screw, cap, socket head	4-5-1
HIC 10-20-16	Nut, adjusting	-2
HIC 10-30-06-B	Screw, correcting	-3
HIC 4-40 x 3/8	Screw, cap, socket head	-4
HIC No. 4	Washer, flat	-5
HIC 4-40 x 1/2	Screw, cap, socket head	-6
HIC No. 4	Washer, flat	-7
HIC No. 5	Washer, lock,	-8
HIC 10-20-16	Nut, adjusting	-9
HIC 10-30-03	Eccentric, correcting	-10
HIC 4-40 x 1/8	Setscrew	-11
HIC 10-30-05-B	Bracket, correcting screw	-12
HIC 10-30-31	Stud, correcting screw bracket.	-13
HIC No. 4-40	Nut, flexlock	

<sup>1</sup> See footnote at end of table.

**Section III A.**  
**REPAIR PARTS LIST, BAROMETER, MERCURIAL,**  
**TYPE A-1 AND BAROMETER, METRIC MERCURIAL,**  
**TYPE A-1 MODIFIED-Continued**

Manufacturer's Part Number	Nomenclature	Figure and Index Number
<sup>1</sup> HIC 10-30-10-B	Index, temperature	-15
HIC 4-40 x 3/8	Screw, cap, socket head	-16
HIC 10-30-13-B	Arm, camrod	-17
HIC 4-40 x 1/8	Setscrew, socket head	-18
HIC 10-30-15	Scale, temperature and gravity.	-19
HIC 3-56 x 3/16	Screw, round head	-20
HIC No. 3	Washer, flat	-21
HIC 10-30-16-B	Block, gravity index	-22
HIC 10-20-04	Bracket, adjusting rod clamping.	4-6-1
HIC 4-40 x 3/4	Screw, cap, socket head	-2
HIC 10-20-16	Nut, locking	-3
HIC 10-20-15	Bushing, clamp	-4
HIC 4-40 x 1/4	Screw, cap, socket head	-5
HIC 10-30-23-A	Spring, correcting lever bracket.	-6
HIC 10-30-25-A	Screw, correcting lever	-7
HIC 10-30-21-A	Bracket, cam follower	-8
HIC 10-30-26	Cam, follower	-8
HIC 10-30-32	Pin, dowel cam follower	-9
HIC 10-20-23	Pin, correcting lever	-10
HIC 10-20-14-A	Pin, correcting	-11
HIC 10-20-11	Lever, correcting	-12
HIC 10-20-10-B	Screw, correcting lever	-13
HIC 20-10-B	Vernier	-14
HIC 0-80NF-2 x 1/8	Screw, machine, fillister head.	-15
COML	Lamp, 3v 0.19 amp (G.E. No. 323).	-16
HIC 10-21-01	Bracket, light	-17
HIC 10-20-09	Ring, sighting	-18
HIC 0-80NF-2 x 3/32	Screw, machine, fillister head.	-19,20
HIC 10-20-17-B	Slide, sighting ring	-21
HIC 10-20-20-A	Strip, contact	-22
HIC 0-80NF x 3/32	Screw, machine, fillister head.	-23
HIC 10-20-21-A	Strip, contact insulating	-24
HIC 4-40 x 3/6	Screw, cap, socket head	-25
HIC 81-26-05	Magnifier	-26
HIC 10-20-07-A	Post, magnifier	-27
HIC 4-40 x 1/4	Screw, cap, socket head	-28
HIC 10-20-24	Strip, vernier	-29

<sup>1</sup> See footnote at end of table.

**Section III A.**  
**REPAIR PARTS LIST, BAROMETER, MERCURIAL,**  
**TYPE A-1 AND BAROMETER, METRIC MERCURIAL,**  
**TYPE A-1 MODIFIED-Continued**

Manufacturer's Part Number	Nomenclature	Figure and Index Number
<sup>1</sup> HIC 0-80NF-2 x 1/8	Screw, machine, fillister head.	4-6-30
HIC 10-20-18	Slide, vernier	-31
HIC 10-10-06-B	Nut, gland	4-7-1
HIC 10-10-17-A	Washer, tube cup	-2
HIC 10-10-18-A	Packing, o-ring hydraulic	-3
HIC 10-10-22	Packing, o-ring, tube cushion	-4
HIC 10-11-00	Nipple subassembly	-5
HIC 10-10-12-A	Gasket	-6
HIC 10-10-01-A	Plug, shipping	-7
HIC 10-10-12-A	Gasket	-8
HIC 10-10-11-B	Lid, cistern	-9
HIC 10-10-10-C	Gasket, cistern	-10
HIC 10-10-13-B	Cistern	-11
HIC 10-10-03-A	Nut, cistern	-12
HIC 10-10-12-A	Gasket	-13
HIC 10-10-02-A	Stud, cistern	-14
HIC 10-10-05	Screw, stop	-15
HIC 10-10-04	Screw, mercury locking	-16
HIC 10-10-14-B	Base, barometer	-17
HIC 10-50-00-A	Cover, level	4-8-1
HIC 4-40 x 1/4	Screw, machine, binding head	-2
COML	Plaster	-3
HIC 10-55-01	Level, bubble	-4
HIC 10-50-12-A	Screw, leveling	-5
HIC 10-50-21	Cover, calibration	-6
HIC 10-50-22	Chart, calibration	-7
HIC 4-40 x 1/4	Screw, machine, binding head	-8
HIC 10-50-19	Drawer	-9
HIC 10-50-18	Knob, drawer	-10
HIC 6-32 x 1/4	Screw, machine, binding head	-11
HIC 10-60-04	Screw, battery	-12
HIC 10-53-01-A	Tube, battery case	-13
HIC 10-53-02	Plug, battery case	-14
COML	Battery, dry, standard flash light type. Signal Corps type C.	
HIC 10-52-03	Screw, contact	-15
HIC No. 5-40	Nut, hexagon	-16, 17
HIC 10-52-04	Spring, contact	-18
HIC 10-52-03	Bushing, contact	-19
COML	Terminal, wire, solderless	-20
HIC COML	Wire, AWG No. 32, PVC insulated, 12 in. lg.	-21

<sup>1</sup> See footnote at end of table.

**Section III A.**  
**REPAIR PARTS LIST, BAROMETER, MERCURIAL,**  
**TYPE A-1 AND BAROMETER, METRIC MERCURIAL,**  
**TYPE A-1 MODIFIED-Continued**

Manufacturer's Part Number	Nomenclature	Figure and Index Number
1 HIC 1/8 in. wire size	Clamp, cable	4-8-22
HIC 4-40 x 1/4	Screw, steel	-23
HIC 17-B-203	Switch, pushbutton	-24
HIC 7/16-24-NF	Nut, binding	-25
HIC 13N12935	Receptacle assembly	-26
HIC 13N12935A	Receptacle	-26A
HIC 13N12935B	Nut	-26B
HIC 13N12935C	Insulator	-26C
HIC 13N12935D	Nut, Insulator	-26D
HIC 10-50-23	Plate, identification	-27
HIC 2-56 x 3/16	Screw, machine, socket head	-28
HIC 10-50-17	Platform	-29
HIC 10-00-18	Cover, dust	

<sup>1</sup> HIC-Hass Instrument Corporation, 6173 Branch Ave., Washington, D.C. 20031.

**Section III B. REPAIR PARTS LIST,**  
**POWER DRIVEN ROTARY VACUUM PUMP 4310-203-3057**

Manufacturer's Part Number	Nomenclature	Figure and Index Number
<sup>1</sup> CSC 92000RW	Cover, assembly	4-9-1
CSC 92000RM	Gasket, cover	-3
CSC 92000RS	Ring, seal carbon	-8
CSC 92000RL	Seal assembly, shaft	-9
CSC P60681	Shaft	-10
CSC 92000RV	Ring, retaining	-12
CSC 92000RT	Ring, retaining	-13
CSC P60693	Bearing, thrust	-14
CSC P60138	Case, pump	-16
CSC P60007	Plate, center	-17
CSC P60006	Plate, side	-19
CSC 92000RN	Plate, valve retainer	-20
CSC 965008	Key, shaft	-21
CSC 92000RB	Ring, intake	-25
CSC 92000RA	Ring, exhaust	-27
CSC P60008	Plate, end	-28
CSC P60003	Rotor	-30
CSC P63003	Pin, spring	-31
CSC 92000RP	Ball, valve	-32

<sup>1</sup> See footnote at end of table.

**Section III B. REPAIR PARTS LIST,  
POWER DRIVEN ROTARY VACUUM PUMP 4310-203-3057-Continued**

Manufacturer's Part Number	Nomenclature	Figure and Index Number
CSC P60599	Vane, exhaust	-33
CSC P63002	Bushing, spring arm	-34
CSC P60011	Stop, vane	-35
CSC P60598	Vane, intake	-36
CSC P60004	Arm, spring lever	-37
CSC 92000RK	Spring, vane	-38

<sup>1</sup> CSC - Central Scientific Company, 1700 W. Irving Park Road, Chicago, Illinois 60613.

**Section III C. REPAIR PARTS LIST,  
POWER DRIVEN VACUUM PUMP 4931-929-8403**

Manufacturer's Part Number	Nomenclature	Figure and Index Number
<sup>1</sup> WSC 2-01-6308	Setscrew, pulley 5/16-18 x 1/2.	4-10-1
WSC 41-2191	Pulley	-2
WSC 1401E	Seal, oil	-3
WSC 41-0643	Gasket, seal	-4
WSC 41-0624	Key	-5
WSC 4, '060	Ring, shaft, retaining	-6
WSC 41-1150	Ring, retaining	-7
WSC 41-0613	Key, woodruff	-8
WSC 2-00-2705	Screw, fillister head, steel 10-32 x 5/16.	-9
WSC 41-1049	Legs	-10
WSC 41-1267	Washer, rubber	-11
WSC 41-1268	Disc, glass	-12
WSC 41-1266	Washer, tension	-13
WSC 41-1047	Case, oil	-14
WSC 41-1345	Cap, dust	-15
WSC 41-1052	Gasket	-16
WSC 2-01-0332	Screw, hex head, steel, 5/16-18'x 2.	-17
WSC 41-2363	Washer	-18
WSC 41-1045	Plate, front	-19
WSC 41-1040	Rotor	-20
WSC 41-1239	Valve, spring	-21
WSC 2-71-0040	Washer, brass No. 10	-22
WSC 2-00-2705	Screw, fillister head, steel 10-32 x 5/16.	-23
WSC 41-1056	Washer	-24
WSC 41-1039	Plug	-25

<sup>1</sup>See footnote at end of table.



**Section III C. REPAIR PARTS LIST,  
POWER DRIVEN VACUUM PUMP 4931-929-8403 Continued**

Manufacturer's Part Number	Nomenclature	Figure and Index Number
<sup>1</sup> WSC 41-1044	Plate, center	4-10-26
WSC 41-1285	Washer, steel	-27
WSC 41-0890	Filter, air	-28
WSC 41-0383	Gasket	-29
WSC 41-1048	Chamber, intake	-30
WSC 41-0920	Nipple	-31
WSC 2-01-0520	Screw, hex head, steel 3/8-16 x 1 1/4.	-32
WSC 41-1055	Plate, back	-33
WSC 41-1255	Shaft, end	-34
WSC 2-00-2708	Screw, fillister head, steel 10-32 x 1/2.	-35
WSC 2-31-2521	Nut, steel 3/8 x 16, hex	-36
WSC 41-2563	Ring, outer	-37
WSC 41-1041	Rotor	-38
WSC 41-1063	Holder, spring	-39
WSC 41-1304	Spring	-40
WSC 41-1059	Vane	-41
WSC 2-01-6112	Screw, socket head, steel 1/4-20 x 3/4.	-42
WSC 41-1042	Ring, inner	-43
WSC 41-0056	Gasket	-44
WSC 41-0578	Seal	-45
WSC 41-1061	Cover, oil cover	-46
WSC 2-10-2608	Screw, fillister head, steel 8-32 x 1/2.	-47
WSC 2-09-1202	Screwstick, self-tapping 1-72 x 1/8.	-48
WSC 41-1936	Plate, pump instruction	-49
WSC 41-1166	Cap, oil drain	-50
WSC 41-1192	Disc	-51
WSC 41-1168	Fitting, brass	-52
WSC 2-01-5308	Screw, round head, steel 5/16-18 x 1/2.	-53

<sup>1</sup> WSC - Welsch Scientific Co., 7300 North Linder Ave., Skokie, IL 60076..

**Section III D. REPAIR PARTS LIST,  
CONSTANT VACUUM REGULATOR 6685-306-5604**

Manufacturer's Part Number	Nomenclature	Figure and Index Number
<sup>1</sup> WTI FU-3424	Valve, vacuum pump	4-11-1
WTI P-538-1/16 in.	Packing, asbestos yarn	-2
WTI CPH-500-1/4 in.	Adapter, hose	-3
WTI CPH-21772	Screw, machine, socket head 1/4-20 x 1/2.	-4

<sup>1</sup> See footnote at end of table.

**Section III D. REPAIR PARTS LIST,  
CONSTANT VACUUM REGULATOR 6685-306-5604-Continued**

Manufacturer's Part Number	Nomenclature	Figure and Index Number
1 WTI CPH-5988	Screw, machine, round head 8-32 x 1/2.	4-11-5
WTI FP-5737	Stud, handle	-6
WTI FP-5736	Handle	-7
WTI CPH-5663	Washer	-8
WTI FP-8108	Wheel, crank	-9
WTI FP-8094	Seal	-10
WTI FU-3881	Bearing, thrust	-11
WTI FP-8096	Washer, facing	-12
WTI FP-8097	Washer, spring	-13
WTI FP-8095	Nut, locking split	-14
WTI P-37633	Screw, machine, round head 4-40 x 1/4.	-15
WTI FU-3877	Stud, tension	-16
WTI FU-3878	Spring, control	-17
WTI FP-8095	Nut, locking split	-18
WTI P-27108	Screw, round head 4-40 x 3/16.	-19
WTI FU-3876	Housing, upper	-20
WTI P-36562	Packing, preformed (O -ring).	-21
WTI FP-5738	Bushing	-22
WTI CPN-3675	Screw, machine, round head 8-32 x 5/8.	-23
WTI P-11149	Washer	-24
WTI FP-8098	Spider	-25
WTI P-12850	Washer, lock	-26
WTI FP-5381	Cross bar	-27
WTI FP-5373	Retainer, spring	-28
WTI FP-5372	Spring	-29
WTI FP-7440	Disc, valve	-30
WTI FP-7441	Retainer, seat	-31
WTI FP-7445	Spacer	-32
WTI P-9933	Nut, hexagon, 5/16-32	-33
WTI FU-3428	Valve inlet and tube	-34
WTI FU-3427	Bellows unit	-35
WTI FP-7442	Gasket	-36
WTI FP-8101	Seal	-37
WTI P-26822	Packing, performed (O- ring).	-38
WTI CPN-2247	Washer, flat	-39
WTI CPN-13180	Nut, hexagon, 3/8-24	-40
WTI E-383	Wax, sealing	-41
WTI CPH-31438	Screw, machine flat head, 6-32 x 1/2.	-42
WTI FP-8103	Cap	-43
WTI FU-3875	Inlet tube	-44

<sup>1</sup> See footnote at end of table.

**Section III D. REPAIR PARTS LIST,  
CONSTANT VACUUM REGULATOR 6685-306-5604-Continued**

<b>Manufacturer's Part Number</b>	<b>Nomenclature</b>	<b>Figure and Index Number</b>
<sup>1</sup> WTI FP-8102	Gasket	4-11-45
WTI P-30066	Packing, performed (O- ring).	-46
WTI CPH-24184	Screw, machine, round head, 8-32 x 3/8.	-47
WTI FR-8113	Housing, lower	-48

<sup>1</sup> WTI - Wallace and Tiernan, Inc., 25 Main St., Belleville, N.J. 07109.

## INDEX

	Paragraph	Page
Adjustment:		
Gravity .....	3-5a(3)	3-4
Preliminary barometer .....	3-5a(2)	3-2
Air bubble, removal .....	4-5d	4-7
Altimeters, calibration .....	3-13	3-13
Altitude to pressure conversion .....	3-13b	3-15
Applied correction vernier readings.....	4-5c	4-6
Barometer frame assembly, construction .....	1-7	1-5
Barometer tube assembly, construction .....	1-7	1-5
Batteries:		
Installation on receipt .....	3-4	3-2
Replacement .....	4-5g	4-8
Calibration, barometer .....	4-15	4-30
Cistern and base:		
Assembly.....	4-14b	4-29
Construction .....	1-7	1-5
Disassembly .....	4-12	4-10
Computing-correcting mechanism, functional description.....	2-4	2-2
Cleaning, barometer .....	4-13	4-28
Compensation features, barometer .....	2-1c	2-1
Constant vacuum regulator (See regulator, constant vacuum).		
Constants used in barometer construction (Table 3-1) .....	3-9c	3-9
Controls, barometer .....	3-6	3-6
Corrections:		
Application .....	2-5	2-2
Applied to scale and index.....	2-6	2-3
Data:		
Barometer (table 1-1) .....	1-84	1-8
Constant vacuum regulator (table 1-2).....	1-8b	1-10
Vacuum pump (table 1-2) .....	1-8b	1-10
Destruction .....	5-2	5-2
Differences among models .....	1-4	1-1
Discrepancies, reporting .....	3-3	3-1
Dismantling, barometer .....	4-12	4-10
Equivalent values, mercury level .....	3-10	3-10
Errors, in manual, report .....	1-6	1-2
Field and depot maintenance allocation .....	1-2	1-1
Field reports of accidents .....	1-5	1-2
Forms, records and reports .....	1-5	1-2
Functional descriptions:		
Barometer .....	2-2	2-1
Computing-correcting mechanism .....	2-4	2-2
Mercury scale .....	2-3	2-2
Vernier .....	2-3	2-2

## INDEX-Continued

	Paragraph	Page
Gravity, adjustment chart .....	2-5	2-2
Inspection:		
On receipt of barometer .....	3-2	3-1
Precision instrumentation .....	3-2 <i>b</i>	3-1
Mechanical parts .....	3-2 <i>a</i>	3-1
Lamp bulb:		
Replacement .....	4-5 <i>f</i>	4-8
Leveling, barometer .....	3-5	3-2
Limitation, barometer .....	2-1 <i>b</i>	2-1
Maintenance, operator's (see operator's maintenance)		
Maintenance, corrective .....	4-11	4-10
Maintenance allocation .....	1-2	1-1
Maintenance technique .....	1-3	1-1
Mercury:		
Removal .....	4-5 <i>b</i>	4-5
Replacement .....	4-5 <i>b</i>	4-5
Mercury column functional description .....	2-3	2-2
Mercury level:		
Checking .....	4-5 <i>a</i>	4-5
Equivalent values .....	3-10	3-10
Sighting .....	3-9 <i>b</i>	3-8
Micrometer, reading .....	3-11	3-13
Model, differences .....	1-4	1-1
Moisture, removal from tube .....	3-5 <i>a</i> (1)	3-2
Mounting platform (see platform assembly)		
Operation, barometer:		
Absolute pressure manometer .....	3-17	3-21
Altimeter calibration instrument .....	3-13	3-14
Barometer .....	3-12	3-14
Constant vacuum regulator .....	3-8	3-7
Differential pressure manometer .....	3-15	3-20
Gage Pressure manometer .....	3-14	3-20
Principles .....	2-1	2-1
Vacuum manometer .....	3-16	3-20
Vacuum pump .....	3-7	3-6
Operator's maintenance:		
Barometer tube .....	4-5	4-5
Batteries .....	4-5	4-5
Lamp bulb .....	4-5	4-5
Parts .....	4-1	4-1
Preventive .....	4-3	4-1
Recording repairs .....	4-8	4-8
Test equipment .....	4-2	4-1
Tools .....	4-1	4-1
Vacuum pump .....	4-6	4-8
Vacuum regulator .....	4-7	4-8
Pump vacuum:		
Assembly .....	4-14	4-29
Disassembly .....	4-12 <i>i</i>	4-23
Maintenance .....	4-12 <i>g</i>	4-23
	4-12 <i>h</i>	4-23
Operation .....	3-7	3-6

## INDEX-Continued

	Paragraph	Page
Reading scale .....	3-10	3-10
Records, operator's maintenance .....	4-8	4-8
Regulator, constant vacuum:		
Adjustment .....	4-14	4-30
Assembly .....	4-14	4-29
Disassembly .....	4-12 <i>m</i>	4-28
Operator's maintenance .....	4-7	4-8
Operation .....	3-8	3-7
Valve replacement .....	4-12 <i>l</i>	4-28
Repairs, recording by operator .....	4-8	4-8
Reports:		
Discrepancies in material received .....	3-3	3-1
Errors in manual .....	1-6	1-2
Scale, reading barometer .....	3-10	3-10
Scale and computing-correcting mechanism:		
Assembly .....	4-14	4-29
Construction .....	1-7	1-2
Disassembly .....	4-12	4-10
Packaging:		
Exterior .....	5-1 <i>g</i>	5-2
Interior .....	5-1 <i>f</i>	5-1
Parts:		
Operator's maintenance .....	4-1	4-1
Physical construction:		
Barometer frame .....	1-7	1-5
Barometer tube .....	1-7	1-2
Cistern and base .....	1-7	1-5
Mounting platform .....	1-7	1-5
Scale and computing:		
Correcting mechanism .....	1-7	1-5
Platform assembly:		
Assembly .....	4-14	4-29
Construction .....	1-7	1-2
Disassembly .....	4-12 <i>f</i>	4-20
Precision instrumentation, inspection .....	3-2 <i>b</i>	3-1
Preparation for use .....	3-5	3-2
Preventive maintenance:		
Chart .....	4-4	4-2
Checks (table 4-1) .....	4-4	4-2
General .....	4-3	4-1
Responsibility .....	4-3 <i>b</i>	4-1
Services (table 4-1) .....	4-4	4-2
Principles of operation .....	2-1	2-1
Scale and computing-correcting mechanism		
Functional description .....	2-4	2-2
Inspection on receipt .....	3-2	3-1
Operator's check .....	4-5 <i>c</i>	4-6
Serial numbers .....	1-4	1-2
Series, models .....	1-4	1-2
Shipment, barometer .....	5-1	5-1
Sighting mercury level .....	3-9 <i>b</i>	3-8
Storage, barometer .....	5-1	5-1

## INDEX-Continued

	Paragraph	Page
Temperature and gravity scale:		
Assembly .....	4-14	4-29
Disassembly .....	4-12c	4-15
Test equipment:		
Maintenance .....	4-2	4-1
Thermometer and scale rod:		
Assembly .....	4-14c	4-30
Removal .....	4-12a	4-11
Tolerances, permissible specific (table 1-1) .....	1-8	1-8
Tools, repair .....	4-1	4-1
Top cap and valve:		
Assembly .....	4-14	4-29
Removal .....	4-12a	4-11
Troubleshooting chart (table 4-) .....	4-10	4-9
Unpacking .....	3-1	3-1
Vacuum pump (See pump, vacuum)		
Valve subassembly, disassembly .....	4-12b	4-13
Vernier readings, applied		
correction (table 4-2) .....	4-5c	4-6
Vernier slide, disassembly .....	4-12d	4-16
Vernier scale, . Functional description .....	2-3	2-2

By Order of the Secretary of the Army:

Official:

VERNE L. BOWERS,  
*Major General, United States Army,  
The Adjutant General*

BRUCE PALMER, JR.,  
General, United States Army,  
*Acting Chief of Staff*

Distribution:

To be distributed in accordance with DA Form 12-34, Section II, (qty rqr block No. 75) requirements for Calibration Procedures Publications.



RECOMMENDED CHANGES TO EQUIPMENT TECHNICAL PUBLICATIONS

 <div style="border: 1px solid black; border-radius: 15px; padding: 5px; display: inline-block; margin-left: 10px;"> <p style="margin: 0;"><i>THEN...JOT DOWN THE DOPE ABOUT IT ON THIS FORM. CAREFULLY TEAR IT OUT, FOLD IT AND DROP IT IN THE MAIL.</i></p> </div>		SOMETHING WRONG WITH PUBLICATION		
		FROM: (PRINT YOUR UNIT'S COMPLETE ADDRESS)		
PUBLICATION NUMBER		DATE SENT		
PUBLICATION DATE		PUBLICATION TITLE		
BE EXACT PIN-POINT WHERE IT IS				
PAGE NO.	PARA- GRAPH	FIGURE NO.	TABLE NO.	<p style="text-align: center; font-weight: bold; margin-top: 0;">IN THIS SPACE, TELL WHAT IS WRONG AND WHAT SHOULD BE DONE ABOUT IT.</p>
PRINTED NAME, GRADE OR TITLE AND TELEPHONE NUMBER			SIGN HERE	

**DA** FORM 1 JUL 79 **2028-2**

PREVIOUS EDITIONS ARE OBSOLETE.

P.S.--IF YOUR OUTFIT WANTS TO KNOW ABOUT YOUR RECOMMENDATION MAKE A CARBON COPY OF THIS AND GIVE IT TO YOUR HEADQUARTERS.

**PIN: 028042-000**